



INSTRUCTION MANUAL REPAIR PARTS LIST

SHOP PRESSES

12 Ton (10886) Capacity
Part Code H68065 (With Hydraulics)
Part Code H68067 (Without Hydraulics)

25 Ton (22680) Capacity
Part Code H68066 (With Hydraulics)
Part Code H68068 (Without Hydraulics)



WARNING



1. Read, study, and understand, all warnings and operating instructions furnished with this press before use.
2. Always use an accurate pressure gauge to measure pressing force. Do not exceed the rated capacity of this press. Never tamper with hydraulic system pressure settings.
3. Components of this press are specially designed to withstand rated capacity loads. Do not substitute bolts or pins, or any other components. Use only genuine factory replacement parts.
4. Always center load on ram plunger. Offset loads can damage ram or ram mount, and may cause load to eject.
5. Before applying load, be certain all press bed supporting pins are fully engaged. Hydraulic ram collar threads must be fully engaged to ram mount prior to applying a load.
6. Before operating, check for signs of cracked welds, bent bed pins, loose or missing bolts, or any other structural damage. Do not operate if any of these conditions exist. Have repairs made only by factory authorized service centers.
7. Remove all loads from press bed before attempting to adjust bed height. Beware of possible falling bed.
8. Press only on loads supported by press bed. Do not support loads on floor or press frame.
9. When using any accessories such as arbor plates, be certain they are centered on press bed, and are in full contact with the bed.
10. Parts being pressed may splinter, shatter, or be ejected from the press. Due to varied applications, it is your responsibility to always use adequate guards, wear eye protection and heavy protective clothing when operating this press.
11. Keep hands and fingers out of the press and away from parts that may shift and pinch.
12. Do not stand in front of work area where load is applied.
13. It is your responsibility to keep this warning label in place and legible. Replacement labels are available from authorized service centers or the factory. Part No. 68533.
14. Failure to heed these warnings may result in personal injury or property damage.

OWNER'S RESPONSIBILITY

Operation. The owner and/or operator shall have an understanding of these operating instructions and warnings before operating the press. Warning information shall be emphasized and understood. If the user is not fluent in English, the instructions and warnings shall be read to and discussed with the operator in the operator's native language by the purchaser/owner, making sure that the operator comprehends its contents.

Maintenance. The press shall be maintained in accordance with instructions listed under "Maintenance."

Inspection

1. Visual inspection shall be made before each use of the press, checking for leaking hydraulic fluid, and damaged, loose or missing parts.
2. Each press, if subjected to an abnormal load or shock, shall be inspected immediately by an authorized Hein-Werner service center.
3. Owners and/or users should be aware that repair of this equipment may require specialized knowledge and facilities. It is recommended that an annual inspection of the press be made by an authorized service center and that any defective parts, decals or warning labels be replaced with genuine Hein-Werner parts. A list of authorized service centers is available upon request.

Damaged Presses. Any press which appears to be damaged in any way, is found to be badly worn, or operates abnormally SHALL BE REMOVED FROM SERVICE until necessary repairs are made by an authorized service center.

Assembly. (See Illustration, Page 2)

1. Attach (1) base leg (item 3) to each column (items 1 and 2) using (2) bolts, lockwashers and nuts (items 12, 13 and 14) per side. Tighten bolts finger tight.
2. Stand both columns upright, with the mounting holes for the column support (item 4) facing the same direction. Attach column support to both columns using (4) bolts, lockwashers and nuts (items 12, 13 and 14). Tighten bolts finger tight.
3. Attach (2) frame supports (item 6) using (2) bolts, lockwashers and nuts (items 12, 13 and 14) as shown. Tighten bolts finger tight.
4. Slide bed frame (item 15) over both columns until it rests on the floor.
5. Insert (1) 5/8-11 x 4-1/2" bolt (item 8) thru (1) head support (item 5), thru one column, and then thru another head support. Use (2) spacers (item 11) and (1) each lockwasher and nut (items 9 and 10) as shown. Tighten finger tight.
6. Pivot both head supports upward to allow head assembly (item 16) to be installed along bottom flange of head support channel.

7. Lower both head supports simultaneously and insert bolt, spacers, lockwasher and nut (items 8, 9, 10 and 11) to attach both head supports to the opposite column.
8. Install remaining 2 bolts, lockwashers and nuts (items 8, 9 and 10) and 4 spacers (item 11) to attach both head supports to the columns.
9. Tighten all bolts and nuts.
10. Install (2) 3/8-16 x .70" (item 18) bolts into head assembly.
11. Attach pump bracket (item 7) to either column using (3) bolts, lockwashers and nuts (items 12, 13 and 14). Note that bracket can be mounted to either side of the press depending on operator preference.
12. Lift bed frame to desired position, and insert (2) locating pins (item 17). Be certain they are fully engaged in both flanges of each column.

For Presses Equipped with Hydraulics:

13. Screw ram into head assembly. By use of ram collar threads.

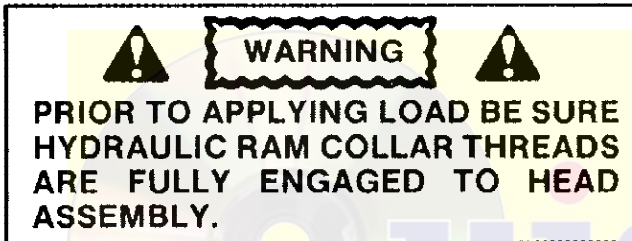

14. Place hand pump on pump bracket and connect hose to ram quick coupler.

OPERATION

1. Bed Frame - The bed frame (item 15) is adjustable up and down to fully take advantage of available ram travel and numerous work pieces.
2. Head Assembly - The head assembly (item 16) is adjustable right to left. To adjust, loosen both hex locking screws (item 18) and position head, always

centering load on ram plunger saddle. After head assembly is positioned hex locking screws must be securely tightened.

BED FRAME ADJUSTMENT

1. Fully retract ram and remove all items from press bed frame.

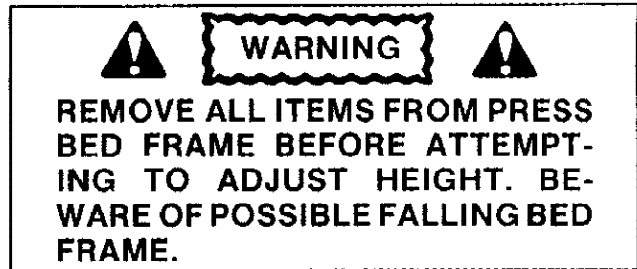

2. Support bed frame, and remove (2) press bed pins (item 17).
3. Raise or lower bed frame to desired height, and reinstall press bed pins. Be certain pins are fully engaged in both flanges of the upright columns.

MAINTENANCE

- Periodically check the press frame to make sure all bolts are tight and inspect for cracked welds, bent, loose, or missing parts.
- If the paint becomes badly chipped, it is suggested that unit be repainted. This will prevent rusting.
- Keep the hydraulic component operating area uncluttered and free of unnecessary equipment.
- Periodically check your hydraulic connections for possible leaks. Replace or properly repair damaged or leaking hydraulic components before using.
- Change hydraulic oil in your hydraulic system every 100 working hours, or more frequently in unusually dirty or dusty areas.

SHOP PRESSES
12 TON PART CODE H68067
25 TON PART CODE H68068

Item No.	Part Code	Description	Qty. Req'd.	
	12 Ton	25 Ton		
1	68709	68727	Left Column	1
2	68710	68728	Right Column	1
3	68711	68711	Base - Leg	2
4	68712	68712	Column Support	1
5	68713	68729	Head Support	2
6	68714	68714	Frame Support	2
7	68715	68715	Pump Bracket	1
8	68716	—	HCS 5/8-11 x 4.5	4
8	—	68730	HCS 5/8-11 x 6.5	4
9	68717	68717	Hex Nut, 5/8-11	4
10	68718	68718	Lockwasher, 5/8	4
11	68719	68719	Spacer	8

Item No.	Part Code	Description	Qty. Req'd.	
	12 Ton	25 Ton		
12	68720	68720	HCS 3/8-16 UNC x 1.0	15
13	68721	68721	Hex Nut, 3/8-16	15
14	68722	68722	Lockwasher, 3/8	15
15	68723	68731	Bed Frame	1
16	68724	68732	Head Assembly	1
17	68725	68725	Press Bed Pin	2
18	68726	68726	HCS 3/8-16 UNC x .70	2
19	68466	—	Bearing Punch	1
20	68465	—	Arbor Plate	2
*21	68539	68540	Product Decal	1
*22	68533	68533	Warning Decal	2

*Not shown.

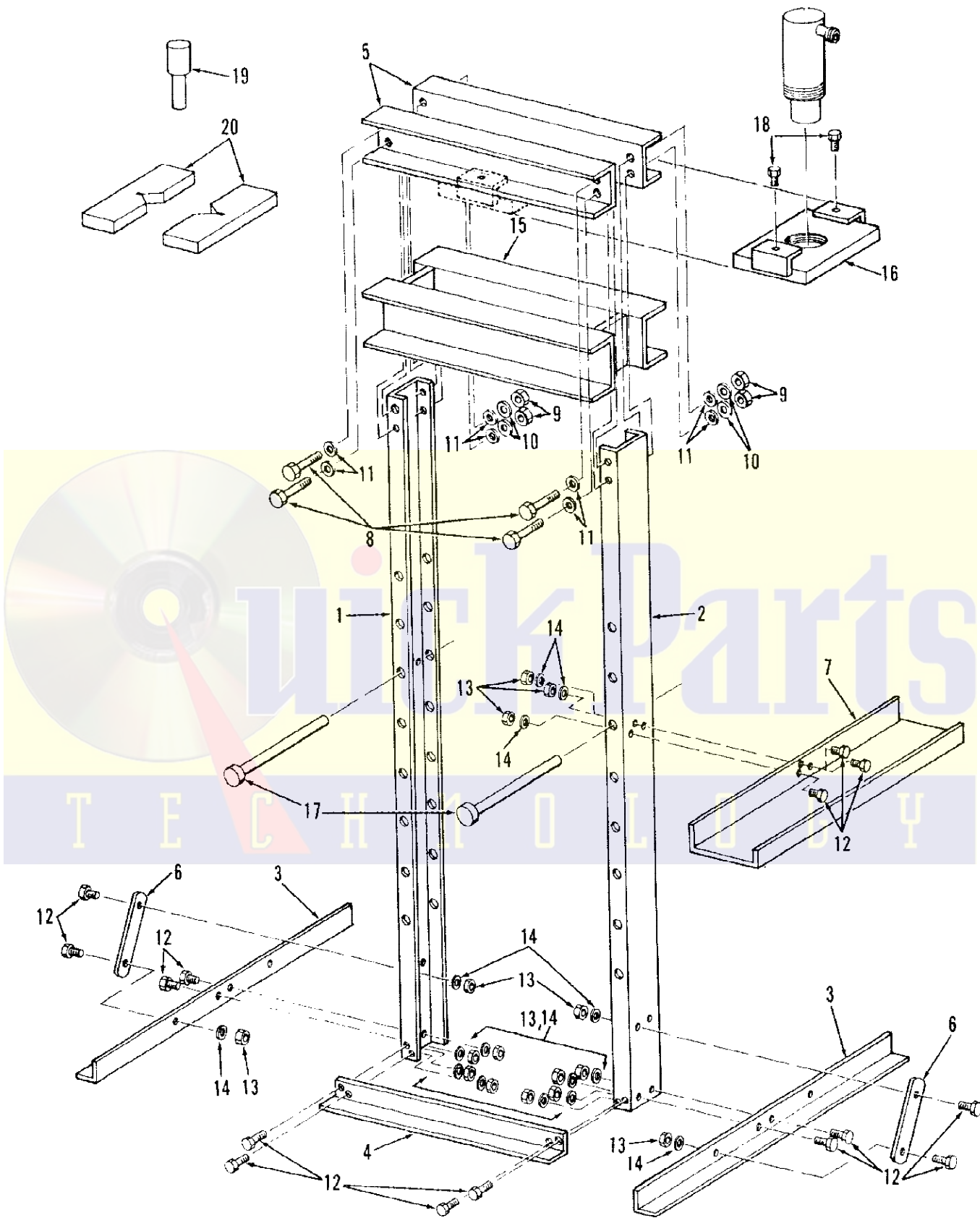

SHOP PRESSES

12 TON PART CODE H68067
 25 TON PART CODE H68068