

US JACK

1½ TON HYDRAULIC
POWER UNIT

PRODUCT INFORMATION

MODEL 5-51901
CRANE MODELS
PART SHEET

OPERATING INSTRUCTIONS

JUNE 2007

PROPER USE

1. When lifting on load rest be sure that load is centered and that lift is perpendicular. Lifting on a angle places excessive side strain on ram. Internal PSI capacity is 10,000 pounds.
2. Do not push load off jack.
3. Always use axle stands when making under vehicle repairs.

A. TO OPERATE

1. Open release valve and pump handle several times. This will eliminate any airbound condition that may have occurred during shipment.
2. Engage the slotted end of the handle with the head of the release screw.
3. Close release valve by turning to right.
4. Insert handle in handle socket and operate the pump.

B. IF JACK WILL NOT OPERATE

1. Release valve may be open— Turn to right to close.
2. No oil in reservoir—with jack in closed position, place in upright position and add hydraulic jack oil through filler plug until oil is level with filler hole. **DO NOT USE ALCOHOL, GLYCERINE, BRAKE FLUID, THICK OR DIRTY OIL.**
3. Intake and pressure valves may be held open by foreign matter— Use operating instructions A-1.
4. Jack will not operate on side —jack may have been placed on wrong side. The side to which the handle socket is attached must be down.
5. Too much oil in the reservoir—Too much oil is liable to cause a vacuum bound jack. The oil should be brought to the level of the fill plug.

C. IF JACK WILL RAISE TO LOAD BUT WILL NOT LIFT IT

1. Release screw may be closed tight enough to raise ram, but not closed tight enough to lift load.
2. Ram may be at extended height—Shim jack up.
3. Ram cup may have become injured or porous, allowing oil to pass it.
4. Air under ram— When there is a quantity of air under the ram, the ram will raise until it hits the load, then it will stay there until there has been sufficient number of pump strokes to compress this air to the proper pressure to lift the load. If this happens, turn jack upside down with ram extended, open release screw and close jack completely. This will cause air to return to oil reservoir.

5. Sticky valves— Empty all oil from reservoir and refill with gasoline or naphtha. Flush as recommended in operating instruction A-1. Then fill with new hydraulic jack oil.

D. IF JACK WILL NOT HOLD LOAD

1. Release valve may not be tight enough.
2. Ram cup may have become injured, allowing oil to pass it.
3. Ball valves may not be seated properly—Flush off as prescribed in operating instructions A-1. The construction of this jack makes the ball valves readily accessible for cleaning. Remove release screw. Remove valves by tipping the jack forward and catching these parts in the hand or a container, place jack on back side with label up to avoid loss of oil. After washing ball valves in kerosene, assemble in reverse order, Replace ball if flat spots or pitted surfaces are found.

MAINTENANCE

1. Refill only with recommended jack oil. Never use a substitute.
2. Use every precaution to prevent entrance of dirt when refilling jack.
3. Store in upright position in a dry place.
4. When stored, the ram should be lowered completely. The pump piston should be in the lowest position and the release valve should be closed.
5. Repair kit 5-577

LUBRICATION

1. Oil all moving parts periodically.
2. Grease should be used on all exposed parts if jacks are constantly used under wet conditions.

100%
American
Made

5-51901 HYDRAULIC UNIT

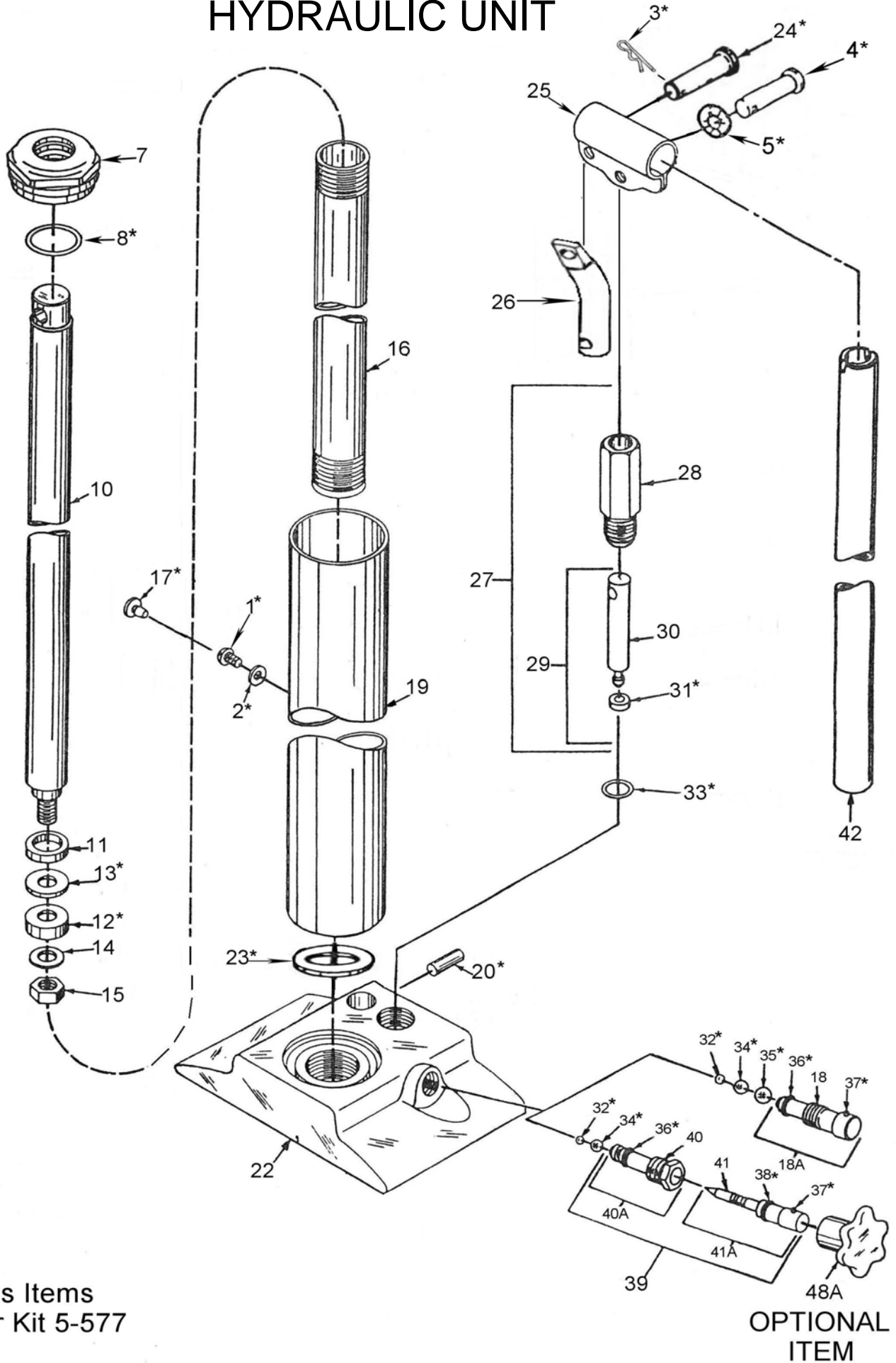

* Denotes Items
in Repair Kit 5-577

OPTIONAL
ITEM

Item No.	Name of Part	1 1/2 Ton 5-51901
1*	Filler Screw	D-2001
2*	Filler Screw Washer	D-2015
3*	Retaining Clip	2-58541
4*	Pump Pin	CH-1028
5*	Retaining Ring	10-11758
7	Reservoir Head	10-11768
8*	"O" Ring	D-2099-17
10	Ram	10-10343
11	Ram Spacer	D-2235-B
12*	Ram Cup	D-2234-A
13*	Ram Cup Backup Washer	D-2240
14	Ram Cup Retainer	D-2236-A
15	Ram Cup Nut	D-2237
16	Ram Cylinder	DP-164-13
17*	Filler Plug	2-54029
18	Release Screw	2-50418
18A	Release Screw Assembly	4-50514
19	Reservoir	DP-164-23
20*	Link Pin	D-2248-A
21	Valve Ball (7/32 Dia.)	D-2074
22	Base	D-2201-C
23*	Brass Washer	2-58490
24*	Handle Socket Pins	10-12019
25	Handle Socket	10-11755
26	Handle Socket Link	10-11785
27	Pump Assembly	4-50518
28	Pump Cylinder	2-50423
29	Piston Assembly	4-54947
30	Pump Piston	2-54945
31*	Piston Cup	10-11760
32*	Valve Ball (7/32)	D-2074
33*	Piston Cylinder Washer	D-2027
34*	Valve Ball (5/16 Dia.)	D-2070
35*	Valve Ball (13/32 Dia.)	D-2075
36*	"O" Ring (5/16 x 7/16) *	D-2099-6
37*	Release Screw Pin	2-58745
38*	"O" Ring (1/4 x 3/8)	D-2099-5
39	Release Screw Assembly	4-58754
40	Release Insert	2-58436
40A	Release Insert Sub-Assembly	4-58462
41	Release Screw	2-58437
41A	Release Screw Sub-Assembly	4-58460
42	Pump Handle	10-12020
48A	Release Knob (Optional)	D-8590

* Denotes items in repair kit

REPAIR KIT 5-577

WARRANTY INFORMATION:

All U.S. Jack manufactured products are warranted for a period of one year against defects in material and workmanship. This warranty is limited to the original consumer purchaser. Warranty does not cover damage due to accident, neglect, or misuse, or products that have been altered or modified, or to which attachments not recommended by the manufacturer have been added. Proof of purchase is required and all warranty claims should be submitted directly to U.S. JACK COMPANY.

WARNING

- A. THIS DEVICE IS A LIFTING DEVICE ONLY. THE LOAD SHALL BE SUPPORTED IMMEDIATELY BY OTHER APPROPRIATE MEANS.**
- B. DO NOT OVERLOAD. OVERLOADING CAN CAUSE DAMAGE TO OR FAILURE OF THE JACK.**
- C. LIFT ONLY ON AREAS OF THE VEHICLE AS SPECIFIED BY THE VEHICLE MANUFACTURER.**
- D. THIS JACK DESIGNED FOR USE ONLY ON HARD, LEVEL SURFACES CAPABLE OF SUSTAINING THE LOAD. USE ON OTHER THAN HARD, LEVEL SURFACES CAN RESULT IN JACK INSTABILITY AND POSSIBLE LOSS OF LOAD.**
- E. FAILURE TO HEED THESE WARNINGS MAY RESULT IN LOSS OF LOAD, DAMAGE TO THE JACK, AND/OR FAILURE RESULTING IN PERSONAL INJURY OR PROPERTY DAMAGE.**

U.S. Jack and American Pride

1125 Industrial Court, Benton Harbor MI 49022
Mailing Address P.O. Box 8826 Benton Harbor MI 49023
PH 269-925-7777 Fax 269-925-6656

Visit our Website: www.usjack.com
Email: sales@usjack.com