



**GRAY MANUFACTURING**  
Company, Inc. • St. Joseph, Missouri

*A tradition of quality since 1952*

3501 S. Leonard Rd.  
St. Joseph, MO 64503  
U.S.A.

Phone: (800) 821-7320  
Fax: (816) 233-7251  
Email: gray@grayusa.com  
grayusa.com

**Parts List**  
**TSL-70**  
**Truck Service Lift**  
**S/N: 946-000297 & Above**

**SERIAL NUMBER REQUIRED ON ALL PARTS ORDERS**

**Final Assembly Parts List**

**946-00001**

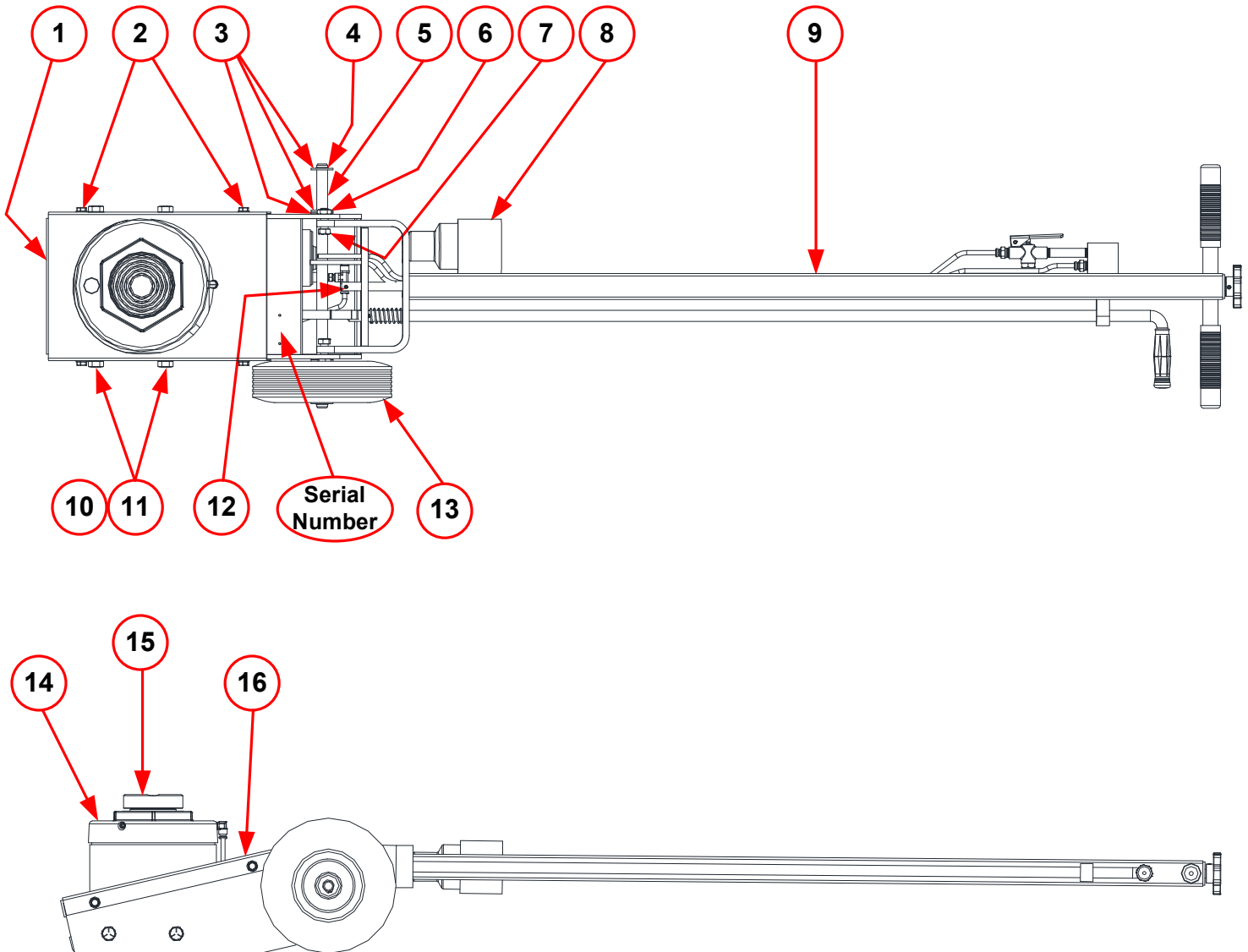

# Final Assembly Parts list

## 946-00001

Item	Qty.	Part Number	Description	Kit
1	1	N/A	Base Frame Weldment	
2	4	202-01103	Screw, Self Tapping, 5/16 x 18 x 5/8" Long	
3	6	204-01614	Washer, Plain 5/8, 1 1/4 OD	
4	2	230-12000	Retaining Ring 5/8" Dia.	^
5	1	850-04028	Grooved Shaft, Axel	
6	2	203-11204	Nut, Hex, Special Jam, 7/16"	
7	2	202-01304	Capscrew, Hex Head, 7/16"	
8	1	946-04013	Lift Pad Extension	
9	1	946-01007	Handle Subassembly	#
10	4	204-11400	Washer, Lock, 1/2", Split	
11	4	200-31406	Capscrew, Hex Head, 1" Long	
12	1	235-21004	Roll Pin, 3/16 Dia. X 3/4" Long	
13	2	480-02006	Wheel, 8" Dia. X 2.500 Hub, 5/8 Bore	^
14	1	353-40108	Power Unit, TSL-70	~
15	1	946-04011	Lift Pad, TSL-70	
16	1	946-04014	Cover	
^	1	8850-01023	Main Wheel Kit – Contains 2 ea. items 4 & 13	^

## Available Kits

Item	Qty.	Part Number	Description	Kit
89-96	1	946-01005	Complete Decal Kit page 7	*
**	1	946-01006	TSL-70 Soft Seal Kit Listed on pages 5 & 6	**
17-73	1	353-40108	TSL-70 Complete Power Unit (both hydraulics & air motor) pg 3 & 4	~
>	1	8850-01012	TSL-70 Complete Air Motor Assembly shown on page 3 & 4	>
4 & 13	1	8850-01023	Main Wheel Kit – Contains 2 ea. items 4 & 13 pg 1	^
74-88	1	946-01007	Handle Subassembly	#

# TSL-70 Power Unit 353-40108

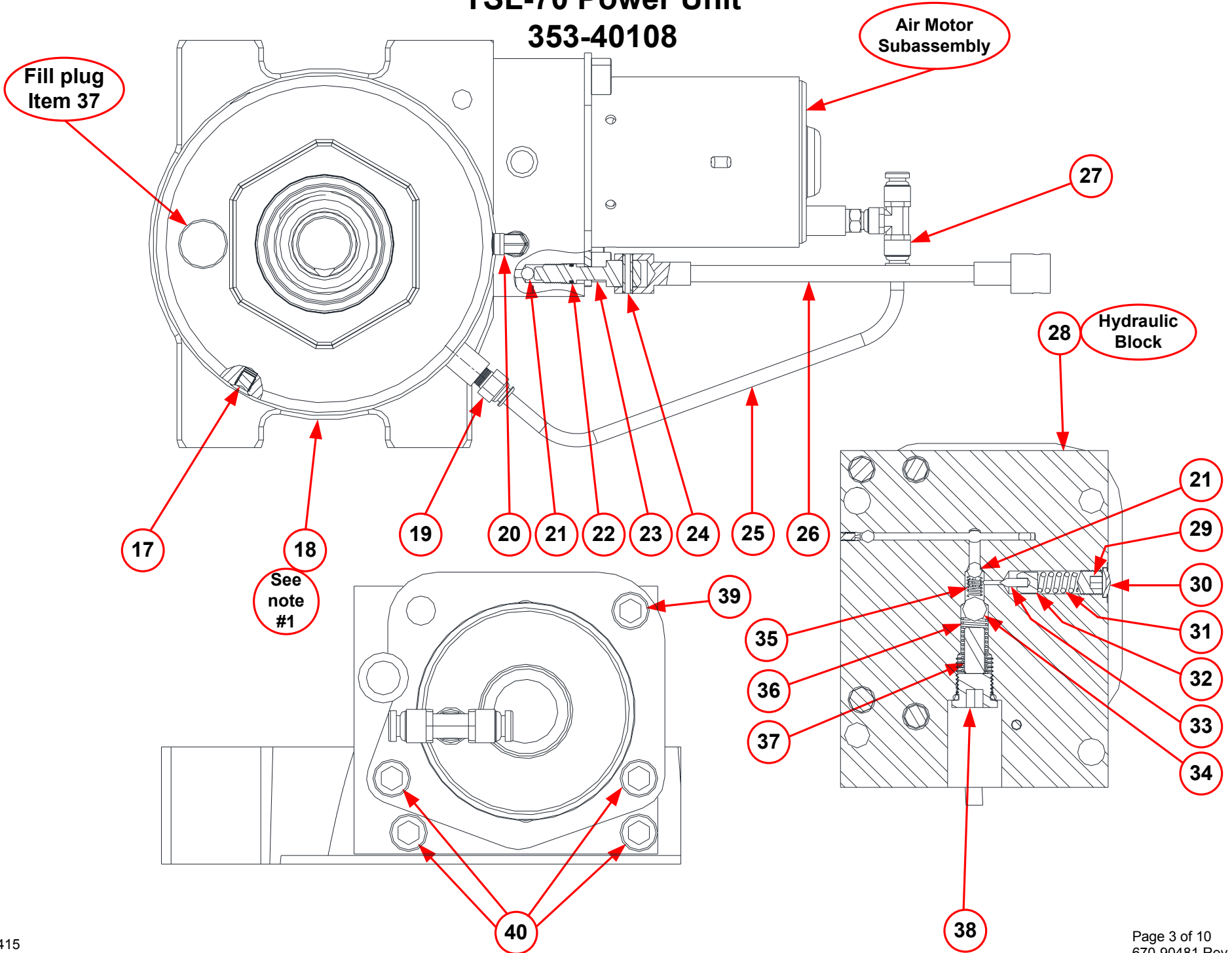

# TSL-70 Power Unit 353-40108

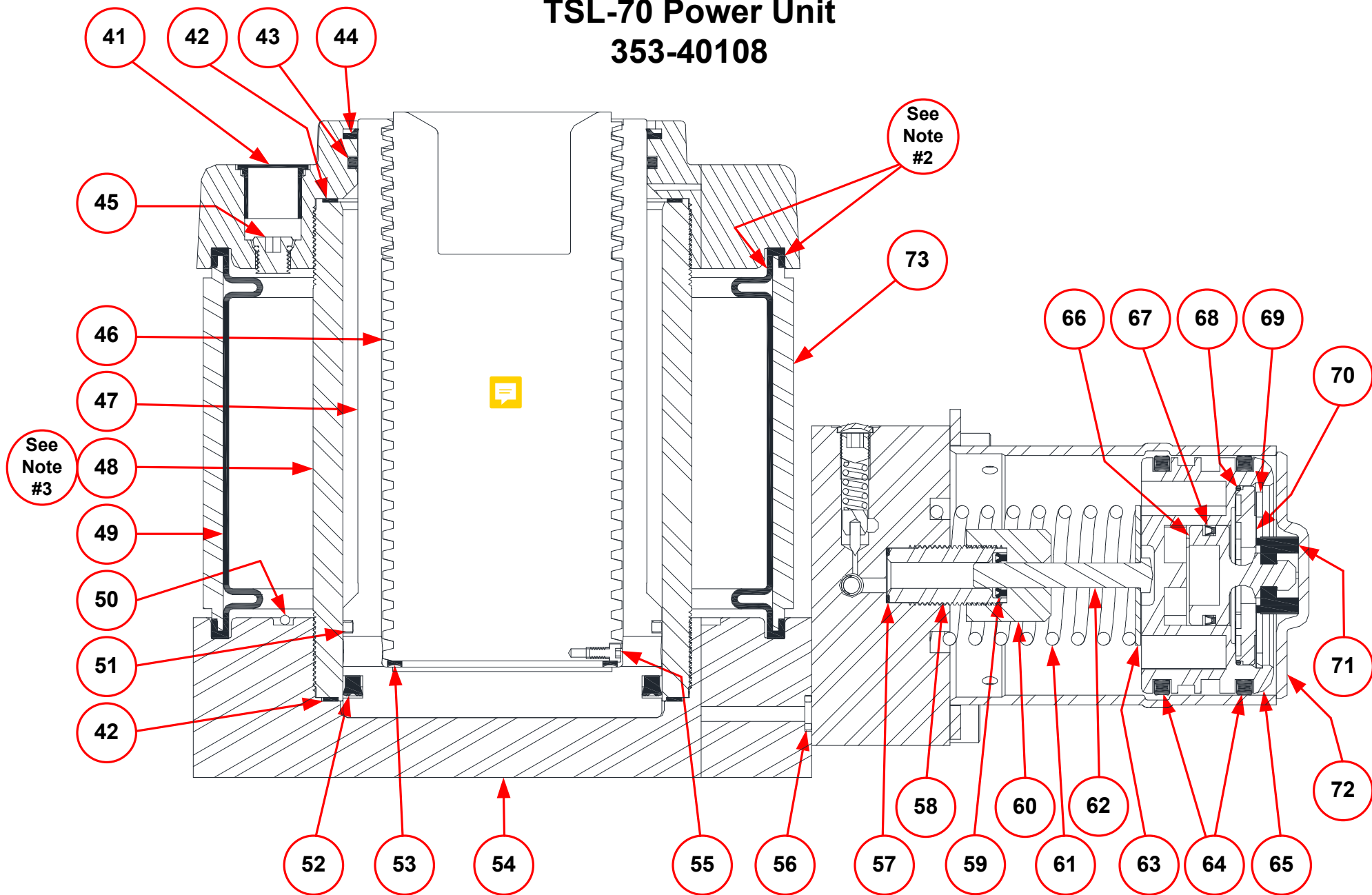

Note 1: Item 18, Jack Cap, is torqued to 1,100 ft. Lbs.

Note 2: If replacing item 49, Bladder, Lubricate these surfaces with STP to prevent twisting of bladder during reassembly.

Note 3: Hydraulic cylinder, outer lip goes toward the top; inner lip goes toward the bottom.

# TSL-70 Power Unit Parts List

Item	Qty.	Part Number	Description	Kit
17	2	275-20010	Hollow Head Hex Plug, 1/8	~
18	1	353-43060	Jack Cap	~
19	1	275-10001	Connector – 1/8 NPT to ¼ tube	~
20	1	275-11005	Elbow 1/8 NPT to ¼ Tube, brass	~
21	2	236-00005	Ball, ¼ Dia.	~
22	1	390-00002	O’Ring 3/8 OD x ¼ ID x 1/16	~, **
23	1	353-49166	Release Stem	~
24	1	235-21004	Roll Pin 3/16 Dia. X ¾”	~
25	1	8082-30027	Tubing, Nylon ¼” OD x 9 5/8”	~
26	1	857-04033	Flex Shaft	~
27	1	275-11006	Tee, ¼ NPT to ¼ Tube, Brass	~
28	1	N/A	Hydraulic Block	~
29	1	N/A	Set Screw, 3/8-24 x 3/8”	~
30	1	N/A	Expansion Plug	~
31	1	N/A	Compression Spring, .312 OD	~
32	1	N/A	Release Guide	~
33	1	NA	Rod, Tapered Release	~
34	1	236-00006	Ball, 3/8 Dia	~
35	1	233-10012	Spring, Compression, ¼ OD x 3/8”	~
36	1	233-12002	Spring, Compression, .406 Dia	~
37	1	353-49162	Check Valve Spacer	~
38	1	274-34001	Plug, Straight Thread, Recessed Socket w/ O’Ring	~
39	1	201-11204	Capscrew, Socket Head, 3/8-24 x ¾”	~
40	4	201-11211	Capscrew, Socket Head, 3/8-24 x 2 ¼”	~
41	1	680-00120	Plug, Plastic	~
42	2	390-11144	Backup Ring, 4 1/8 x 4 ½ x .055	~, **
43	1	390-02023	Quad Ring, 3 7/8 x 3 5/8 x 1/8	~, **
44	1	390-11145	Rod Wiper, 3 5/8 x 4 x 1/8	~, **
45	1	274-32001	Plug, SAE #4	~
46	1	946-04012	Extension Screw	~
47	1	353-42037	Hydraulic Ram 	~
48	1	353-41086	Hydraulic Cylinder	~
49	1	353-49352	Bladder	~
50	1	353-49010	Magnet, 7/16”	~
51	1	390-02022	Quad Ring, 4 x 1/8 x 3 ¾”	~, **
52	1	390-11146	Seal, 4” OD x 3 ½” ID x ¼”	~, **
53	1	390-11142	Backup Ring, 2 ½” x 1/16” x 2 7/8”	~, **
54	1	N/A	Hydraulic Base, TSL-70	~
55	1	201-00602	Capscrew, Socket Head, 6-32 x ¼”	~
56	2	390-10056	Quad Ring, 7/16 x ¼ x 3/32”	~, **
57	1	390-10060	Backup Ring, 11/16 x ½” x .040 thick	~, **
58	1	353-43030	Pump Housing	~
59	1	390-10055	Seal, 6/16 x 5/16 x 1/8”	~, **
60	1	353-43029	Pump Housing Cap	~
61	1	233-15003	Spring, Compression, 1 ¾” OD	~
62	1	353-49156	Pump Plunger	~
63	1	204-01106	Washer	~
64	2	390-02010	Quad Ring, 3” OD x 2 5/8” ID x 3/16”	~, **, >
65	1	310-41017	Piston, Air Motor, Injected Molded	~, >

Item	Qty.	Part Number	Description	Kit
66	1	310-40004	Air Shuttle Piston, Injection Molded	~, >
67	1	390-10076	Seal, 1 1/4" OD x 1" ID x 1/8"	~, **, >
68	1	390-01061	O'Ring 2 1/4 x 1/16 x 2 1/8"	~, **, >
69	1	230-06001	Retaining Ring, 2 1/8" Dia.	~, >
70	1	310-91014	Piston Cap, Injection Molded	~, >
71	1	315-00002	Seal, Shuttle Valve	~, **, >
72	1	N/A	Air Motor Cylinder Weldment	~, >
73	1	946-02003	Reservoir Tube Weldment	~

## Handle Subassembly 946-01007

Item	Qty.	Part Number	Description	Kit
74	1	232-20094	Hand Wheel, Release Knob	#
75	1	850-04010	Hand Bar, Drilled	#
76	1	232-20128	Handle Grip, 5/8 x 3 1/2"	#
77	2	275-11004	Connector, 1/4" to 1/4" tube	#
78	1	8082-30022	Tubing, Nylon 60"	#
79	1	8850-02007	Handle Release Rod Weldment	#
80	1	233-14012	Spring, Compression	#
81	2	235-21011	Roll Pin 3/16" x 1 1/8"	#
82	2	232-20114	Hand Grip 7/8" x 5"	#
83	2	312-91004	Screen	#
84	1	275-01004	Nipple. 1/4" x 3"	#
85	1	312-00002	Air Valve	#
86	1	8082-30041	Tubing, Nylon 43.5"	#
87	1	N/A	Handle Weldment	#
88	1	N/A	Release Control Rod	#

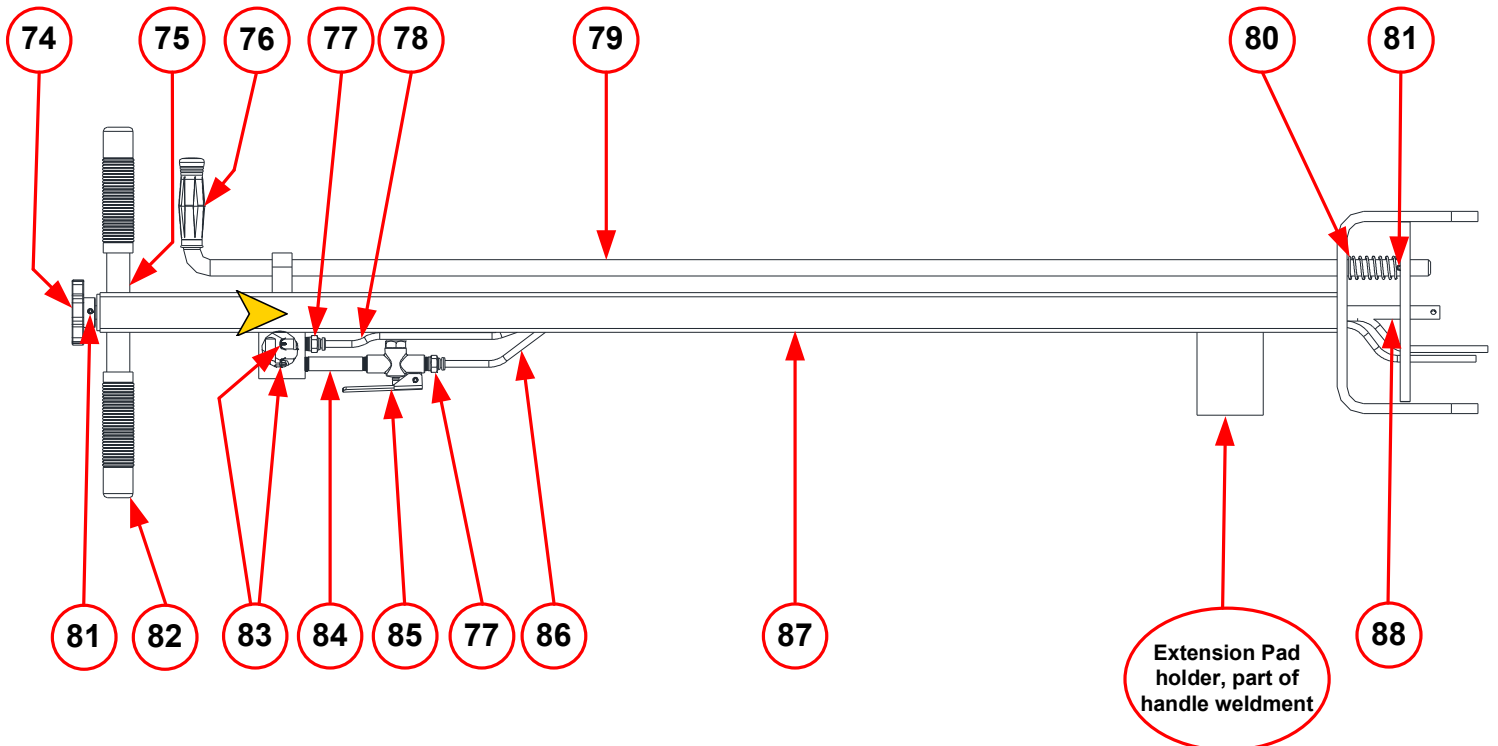

# TSL-70 Placard Parts List

## 946-01005

Item	Qty.	Part Number	Description	Kit
89	1	N/A	Identification Placard, Warning Label, TSL-70	*
90	1	N/A	Information Placard, Quick Coupler	
91	1	N/A	Closure, Plastic, Tapered	
92	1	N/A	Information Placard, Ram Retract	*
93	2	N/A	Notice, Ram Retract	*
94	1	N/A	Information Placard, "Made in USA"	*
95	1	N/A	Information Placard, Warning Label	*
96	1	N/A	Information Placard, Multi Language	*
*	1	946-01005	TSL-70 Complete Decal Placard Kit	*

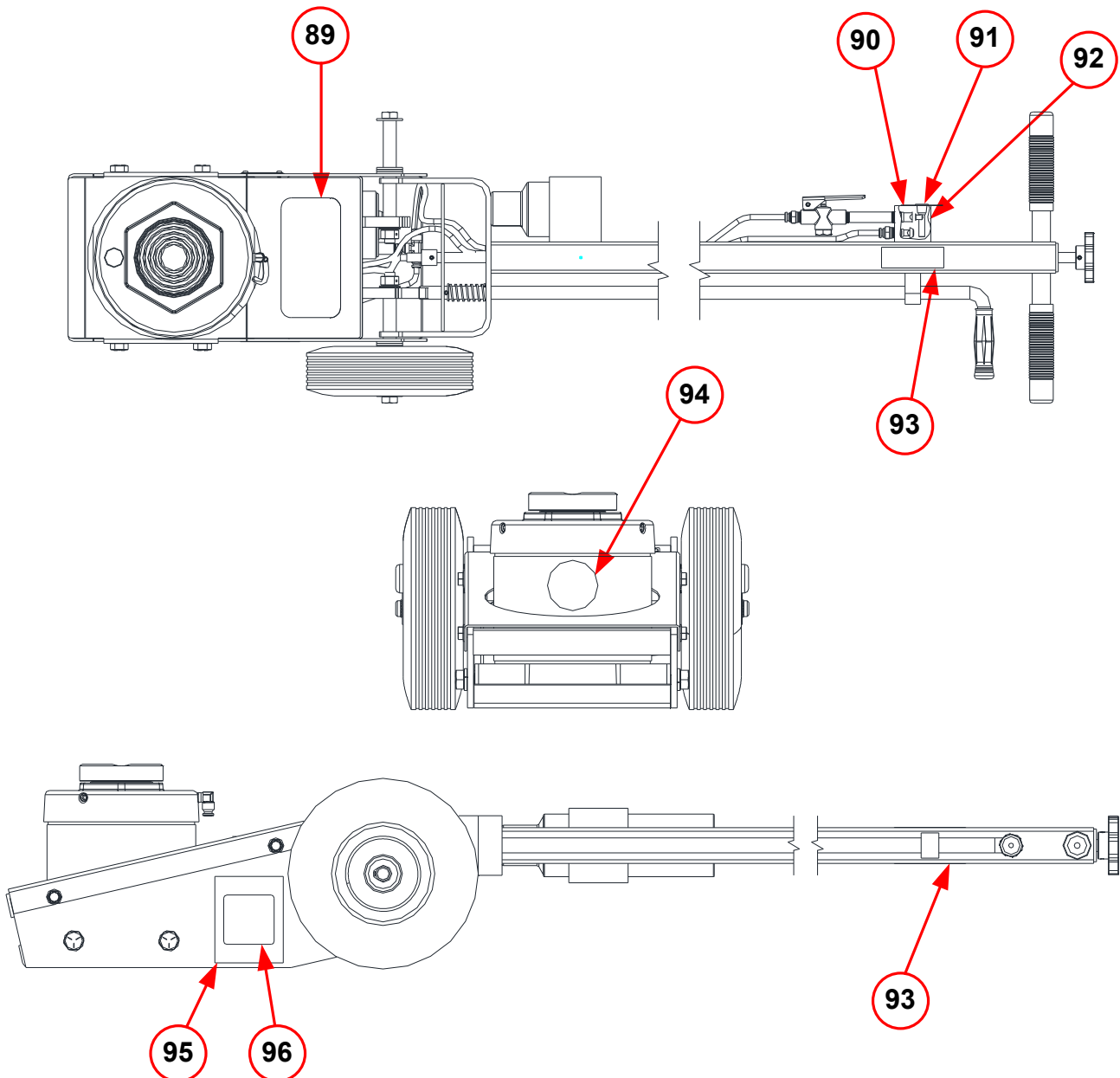

# TSL-70 TROUBLESHOOTING

## **PROBLEM: WILL NOT LIFT LOAD**

### Possible Solutions:

1. Release stem is bent or damaged. Replace if needed.
2. Release knob is not tight enough. Tighten release knob.
3. Check ball is missing from behind the release stem. Install ¼" steel check ball.
4. Unit is low on hydraulic fluid. Replenish with light hydraulic oil only.
5. Air pressure is too low. Raise the PSI going to the jack. PSI should range from 90-200 PSI.
6. Lifting too much weight. Use a lifting device with a higher lifting capacity.
7. Check ball is not seating. Remove, clean and re-seat check balls.
8. Seals are worn. Replace any worn parts if needed.

## **PROBLEM: RAM WILL NOT RETRACT**

### Possible Solutions:

1. Main air supply to jack is not attached. These units have an air powered ram retract feature which requires the main air supply to be attached to the jack for lowering.
2. Oil reservoir is air bound (air has mixed with the hydraulic fluid). Follow this bleeding procedure:  
Leave main air supply attached to the jack. Locate the oil fill plug next to the main lifting ram on the jack. Slowly open the fill plug allowing any air to escape. If air or oil continues to escape then there is possibly an internal problem which may require rebuilding or replacing the power unit. If not replenish oil supply with **light hydraulic fluid only** and re-install fill plug.

## **PROBLEM: AIR MOTOR IS STALLING**

### Possible Solutions:

1. Air pressure is too low. Raise the PSI going to the jack. PSI should range from 90-200 PSI.
2. Air motor piston needs lubricating. Insert a few drops of air tool oil into the airline & cycle jack.
3. Seals or parts are worn. Replace if needed.

## **PROBLEM: JACK IS SLOWLY LEAKING DOWN**

### Possible Solutions:

1. Check balls are not seating. Remove, clean & re-seat check balls.
2. Check ball is missing from behind the release stem. Install ¼" steel check ball.
3. Release knob is not tight enough. Tighten release knob.

## **PROBLEM: AIR IS ESCAPING FROM JACK**

### Possible Solutions:

1. Some small air escaping can be normal. As long as it is not blowing hard enough to move the lift pad or effect the integrity of the lift (the lift itself is not seeping down) some air seepage may be normal.
2. If air escapes from the lift pad area, the seals at the bottom of the hydraulic cylinder need replaced (items 42).
3. If air escapes around the ram, the seals at the top of the hydraulic cylinder need replaced (item 44 & 51.)



## TSL-70 Hydraulic Fluid Checking/Filling Procedures

### Notice:

The oil reservoir in the TSL jack is sealed and pressurized when in use. When checking the fluid level, DO NOT have the jack connected to the air supply.

1. Make sure ram is fully retracted.
2. Disconnect the air line.
3. Carefully remove the plastic fill plug (item 41) from the oil fill hole located on the top surface of the jack body.
4. Make sure the hole for the oil reservoir plug is clean & dry before removing the plug. Water and dirt can damage or destroy the hydraulic parts.
5. Remove plug (item 45) using a 3/16 Hex wrench.
6. Check fluid level. RAM MUST BE FULLY RETRACTED. The oil should be within ¼" of the bottom of the oil fill hole. If fluid is low, add a high-grade hydraulic fluid equivalent to Mobile Tellus T22. DO NOT use brake or transmission fluid.
7. Reinstall & secure the fill plug, replace the plastic plug, and connect to air supply and test for normal operation.

## TSL-70 Air Bleeding Procedures

1. Leave air hose hooked up to jack
2. Open release knob on the top of the handle as if you were letting the jack down.
3. Slowly open the hydraulic fill plug (item 45) located underneath yellow plastic plug (item 41).
4. Allow air to escape; you can help this process by slowly pushing the ram down with your hand if it is already extended. Make sure all air and/or oil stop bubbling out.
5. If air and/or oil stop exhausting out, close fill plug and continue with use.
6. If air and/or oil continue to bubble out, the unit may be in need of repair or you may need to replace the power unit at this time. You may contact Gray's Customer Service Department at this time for parts or service.

## Field Service Instructions TSL-70

The following are precautionary notes to aide you in the reassembly of your TSL-70 jack. All part numbers referred to are found on the Gray TSL-70 Hydraulic Unit Parts List (670-90481 Rev B).

Do not remove any permanently installed plugs. There are no serviceable parts under these plugs.

Do not remove hydraulic cylinder, item 48, if it remains tight in the base plate, item 54.

After complete disassembly all parts should be thoroughly cleaned and dried before reassembly. Care should be taken to keep all contaminants out of the units. Be sure you install all seals correctly. An inverted seal or twisted quad ring will cause the unit to leak, operate abnormally, or not operate at all.

When installing the bladder, item 49, and outer barrel, item 73, the bottom sealing surface of the bladder and the groove in the base plate, item 54, must be completely dry. Set the assembly in place so that the outer barrel/reservoir tube weldment (item 73) is located as shown. Then lubricate the top sealing surface and the top 1/4" of the inside surface of the bladder with a 50-50 mixture of STP and hydraulic oil. This will allow the jack cap, item 18, to spin onto the bladder without twisting it. If the bladder twists, the reservoir will not hold sufficient oil to get full stroke out of the ram. The outer barrel/reservoir tube, item 73, must be held to prevent it from turning when tightening the jack cap, item 18. Be sure you have the 90 degree elbow, item 20, positioned correctly before tightening the jack cap. The jack cap should be tightened to 1100 ft-lbs. After the cap is tight, the reservoir should be filled with 32 oz. of Mobil DTE-11 hydraulic oil or equivalent. Consult the owner's manual for proper filling procedures.

When installing the hydraulic block, item 28, to the base plate, item 54, be sure the two mating surfaces are clean. Also make sure the quad rings, items 56, are installed properly. Assemble the parts using capscrews, item 40, and tighten to 35-40 ft-lbs. Install the air motor assembly using capscrews, items 40 and 39, to the hydraulic block. Use thread locking compound on all capscrews and tighten to 35-40 ft-lbs. Do not add lock washers.

Be sure to install the quad ring, item 44, in the jack cap, item 18.