

Parts List for:

NTW-PA6R-PR
PA6R
PA6R-STAND
PA6RM
PA6RM-DE-STA-CO

MODEL F AIR HYDRAULIC PUMP Max. Capacity: 10,000 PSI

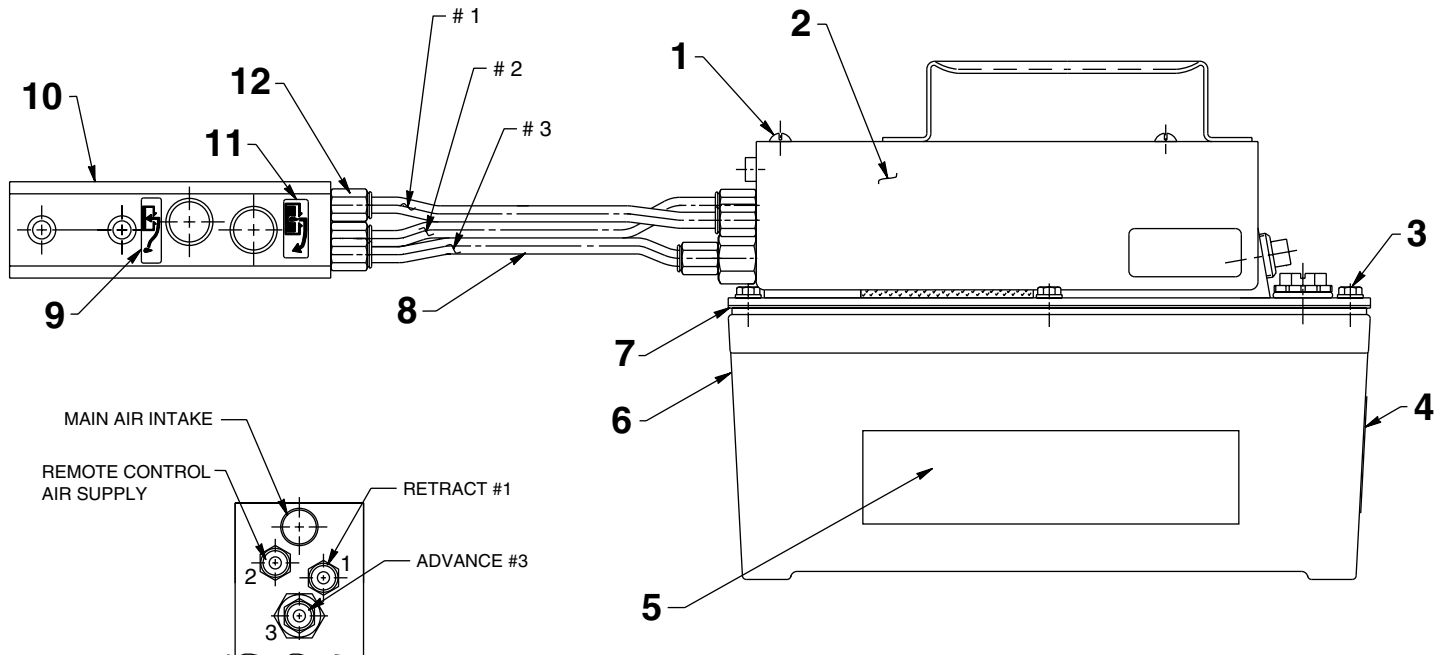

REMOTE CONTROL CONNECTIONS

Connect remote control hose assembly to corresponding numbers on intake block.

Item No.	Part No.	No. Req'd	Description
1	10164	4	Screw (10-24 X 3/8)
2	41605BK2	1	Shroud
3	211060	6	Screw (9-15 X 1; For PA6R, PA6R-STAND, & NTW-PA6R-PR; Torque to 25/35 in. lbs.)
	215952	6	Screw (10-24 X 5/8; For PA6RM & PA6RM-DE-STA-CO; Torque to 35/42 in. lbs.)
4	251762	1	Warning Decal
5	305496CE	1	Trade Name Decal (For PA6R & PA6RM)
	305496	1	Trade Name Decal (For PA6R-STAND & PA6RM-DE-STA-CO)
6	61243	1	Reservoir (For PA6R, PA6R-STAND, & NTW-PA6R-PR)
	41300WH2	1	Reservoir (For PA6RM & PA6RM-DE-STA-CO)
7	*33853	1	Reservoir Gasket
8	253690	12'	Pneumatic Ribbon Hose (Cut to 147.00/142.00 inches long)
9	251760	1	Instruction Decal (RELEASE)
10	421265	1	Air Operated Hand Control
11	251759	1	Instruction Decal (PUMP)
12	250464	6	Straight Fitting (1/8 NPTF)

Part numbers marked with an asterisk (*) are contained in Repair Kit No. 301030.

Sheet No. 1 of 3

Rev. 4 Date: 3 April 2001

TOP & END VIEWS

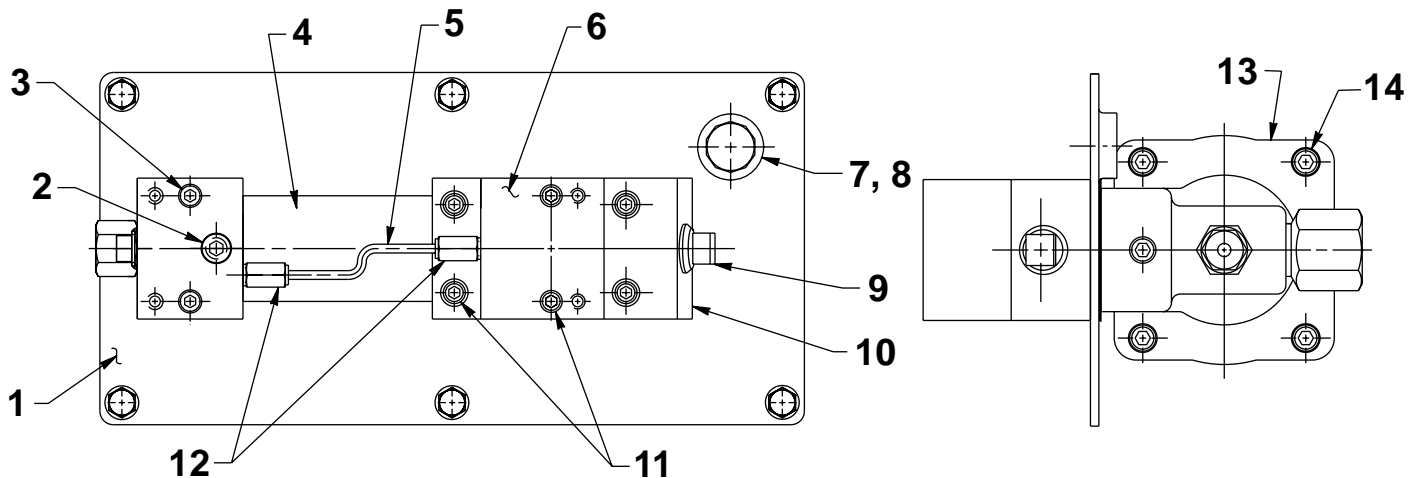

Item No.	Part No.	No. Req'd	Description
1	420965BK2	1	Cover Plate (For PA6R, PA6RM PA6R-STAND, & PA6RM-DE-STA-CO)
	421156BK2	1	Cover Plate (For NTW-PA6R-PR)
2	15499	1	Plug Fitting (1/8 PTF)
3	14423	2	Screw (10-24 X 2)
4	*29992	1	Foam Tube
5	14281	.3 ft	Nylon Tubing
6	34759	1	Piston Relief Valve Body
7	251689	1	Filler/Breather Cap
8	*10273	1	O-ring (.81 X .62)
9	11127	1	Plug Fitting (3/8 NPTF)

Item No.	Part No.	No. Req'd	Description
10	58682	1	Release Valve Body (For NTW-PA6R-PR, PA6R, PA6RM, & PA6RM-DE-STA-CO)
	59015	1	Release Valve Body (For PA6R-STAND)
11	11151	6	Screw (10-24 X 1-1/4"; Torque to 50/60 in. lbs.)
12	250725	2	Straight Fitting (1/16 NPTF)
13	64767	1	Pump Body
14	17428	4	Screw (1/4-20 X 3-1/2"; Torque to 85/95 in. lbs. oiled; Note: Cross torque in increments of 30 in. lbs.)

Part numbers marked with an asterisk (*) are contained in Repair Kit No. 301030.

END VIEW FOR NTW-PA6R-PR ONLY

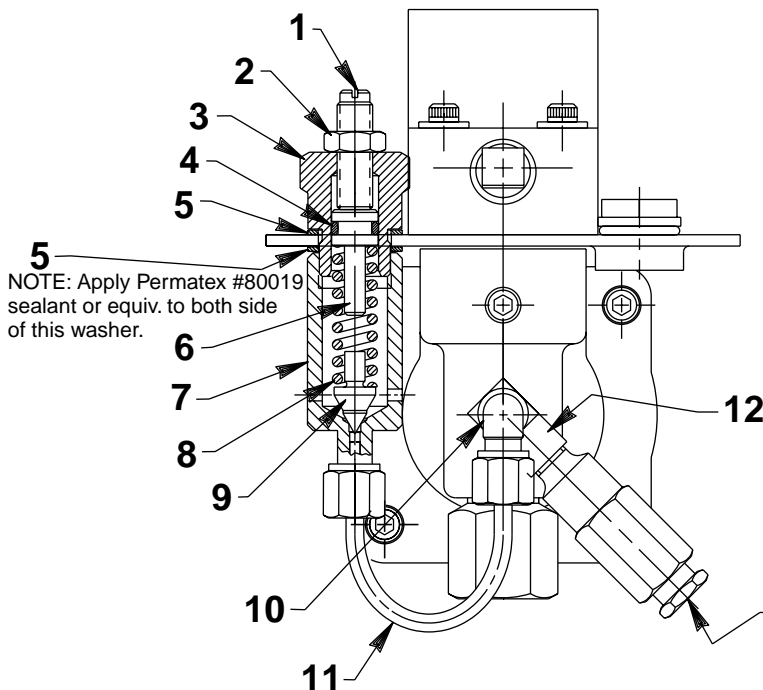

NOTE: Apply Permatex #80019 sealant or equiv. to both side of this washer.

Item No.	Part No.	No. Req'd	Description
1	22362	1	Screw, Adjust (3/8-24 x 1-1/4)
2	10386	1	Nut, Hex Jam (3/8-24)
3	21305	1	Cap, Valve
4	10268	1	O-ring (.50 x .37 Nitrile)
5	10263	2	Washer, Special (1.00 x .77)
6	21306	1	Guide, Spring
7	22361	1	Body, Valve
8	10495	1	Spring (.46 OD x 1.67 x .11 ws)
9	21046	1	Stem, Valve
10	16177	1	Fitting, Elbow 90° (1/8 NPTF)
11	253366	1	Tube, Pressure Regulator
12	18969	1	Fitting, Tee (1/8 NPTF; Apply Loctite 592 [PT #905516] or equiv. & torque to 150/170 in. lbs.)

BASIC PUMP ASSEMBLY

To Parts List

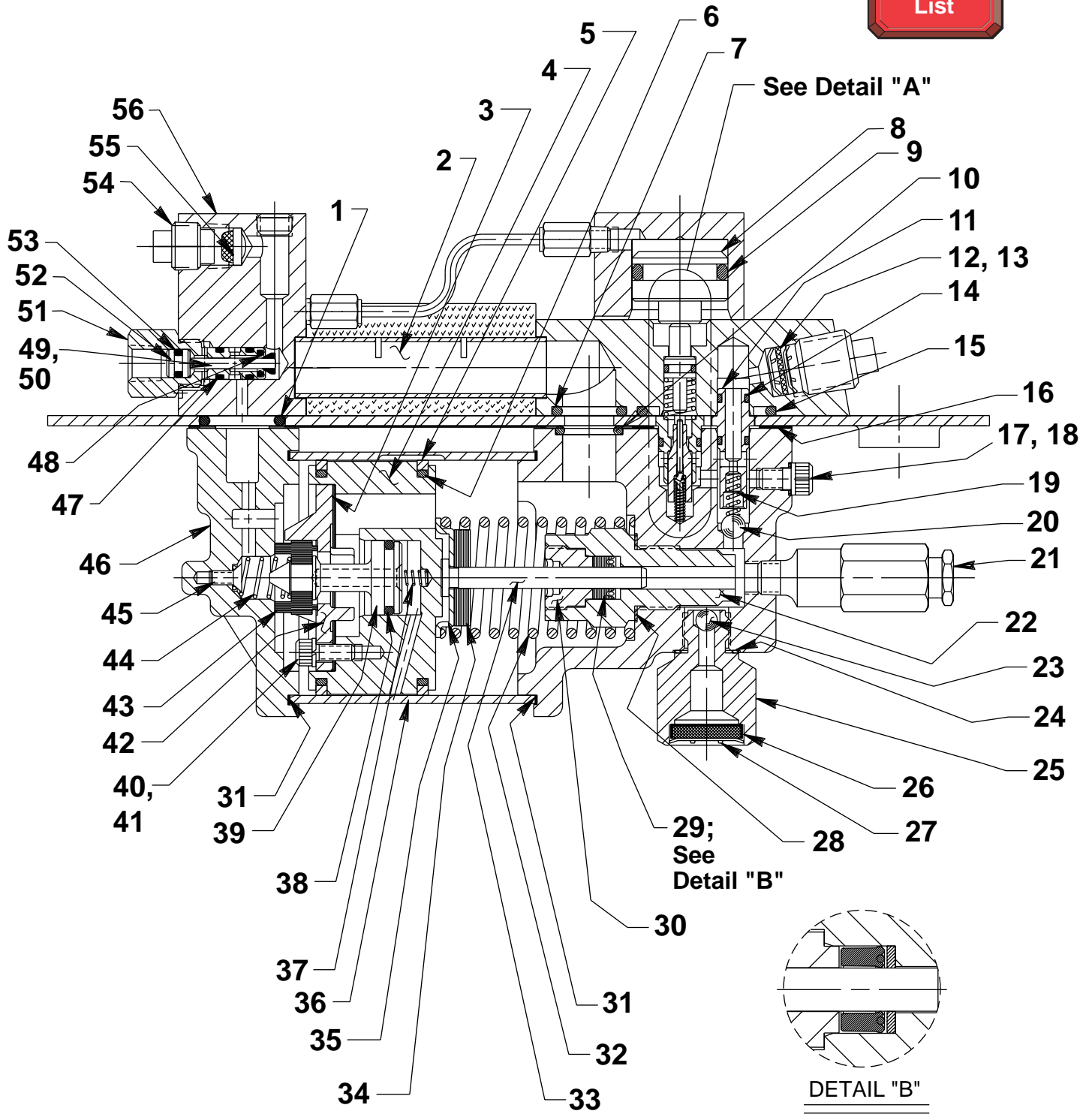

Parts List, Form No. 108119, Back sheet 2 of 3

Item No.	Part No.	No. Req'd	Description
1	*251717	1	O-ring (1.0 X .62)
2	28387	1	Muffler
3	*28239	1	Gasket
4	52390	1	Piston Body
5	*14265	2	Piston Ring
6	*251835	2	O-ring (2-1/2" X 2-5/16" X 3/32 Nitrile)
7	*10276	1	O-ring (1.0 X .75)
8	34757	1	Piston Release
9	*208144	1	O-ring (1.12 X .87; Apply lubricant)
10	*10272	1	O-ring (.75 X .56)
11	34378	1	Check Valve Body
12	*250638	1	Oil Filter Disc
13	*11088	2	Internal Retaining Ring (.31 X .010)
14	*12522	2	O-ring (.37 X .25)
15	*11841	1	O-ring (1.62 X 1.37)
16	*351021	1	Cover Plate Gasket
17	*10442	1	Copper Washer (.37 X .25)
18	10002	1	Screw (1/4-20 X 3/8; Torque to 90/110 in. lbs.)
19	*10445	1	Spring (.16 O.D. X .72)
20	*10423	1	Ball (9/32" dia.)
21	21278	1	Relief Valve (Set at 10,100/10,700 PSI; Apply loctite 592 [Power Team #905516] or equiv. & torque to 150/170 in. lbs.)
22	45278	1	Piston Cylinder (Torque to 90/100 ft. lbs. oiled)
23	*10375	1	Ball (1/4")
24	*10261	1	Washer (.75 X .60)
25	308893	1	Filter Adapter (Torque to 40/50 ft. lbs. oiled)
26	214578	1	Filter
27	214586	1	Internal Retaining Ring
28	*10263	1	Special Washer
29	*13934	1	U-Cup & Backup
30	*304295	1	Retainer (Note: See "INSTRUCTIONS FOR RETAINER REPLACEMENT" on sheet 3 of 3.)
31	*17429	2	Backup Washer (2.94 X 2.75)
32	*13938	1	Spring (1.45 O.D. X 4.4)
33	28226	1	Piston (1/4")
34	203143	1	Bumper
35	210994	1	Spring Guide
36	37434	1	Air Cylinder (Note: Locate groove on upper half (top) of pump with chamfered tube end towards rear head as shown.)
37	*12692	1	Spring (.18 O.D. X 1.70)
38	*211052	1	O-ring (.90 X .70)
39	305475	1	Exhaust Valve Stem
40	*10241	3	Lockwasher (.33 X .20)
41	211054	3	Screw (10-24 X 1/2; Torque to 50/55 in. lbs.)
42	33822	1	Piston End Plate Casting
43	*28183	1	Piston Poppet
44	*205679	1	Spring (.49 O.D. X .92)
45	*205674	1	Screw (8-32 X 3/8; Torque to 12/18 in. lbs.)
46	51480	1	Rear Head
47	*10266	2	O-ring (.37 x .25 Nitrile)
48	*15023	1	O-ring (.31 x .18 Urethane)
49	250278	1	Dowel Pin (.13 x 1.00; NOTE: Press fit pin into poppet [Item #50] until pin end is flush with the flat bottom of poppet.)
50	250277	1	Poppet
51	360009	1	Piston Cartridge
52	250261	1	Piston
53	*12557	1	O-ring (.34 x .21 Nitrile)
54	13272	1	Plug Fitting (1/4 NPT)
55	*216296	1	Filter Disk
56	421941	1	Manifold



Note: Shaded areas reflect last revision(s) made to this form.

DETAIL A

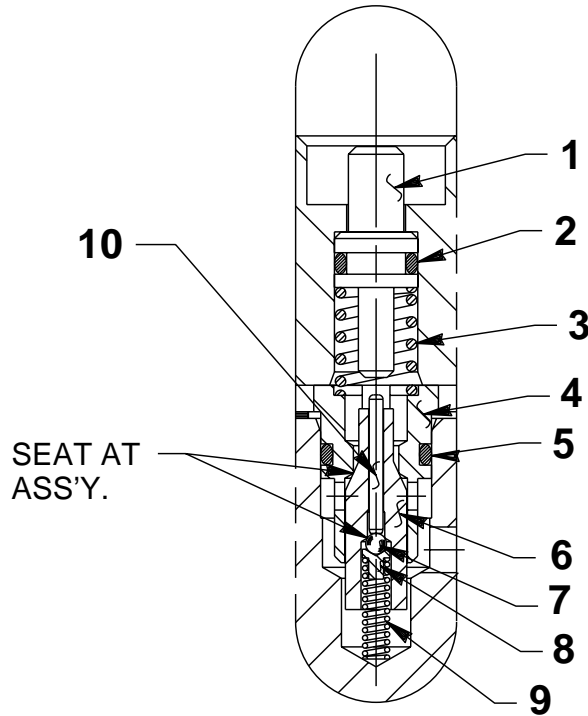

Item No.	Part No.	No. Req'd	Description
1	28227	1	Release Valve Button
2	*10266	1	O-ring (.37 X .25)
3	*13944	1	Spring (.36 O.D. X .50)
4	34377	1	Poppet Retainer
5	*15279	1	O-ring (.50 X .37)
6	29037	1	Release Valve Poppet
7	*14443	1	Ball (3/32")
8	209736	1	Ball Retainer
9	*13959	1	Spring (.12 O.D. X .50)
10	13937	1	Dowel Pin (.06 X .63; Note: Place tapered end toward ball.)

Part numbers marked with an asterisk (*) are contained in Repair Kit No. 301030.

INSTRUCTIONS FOR RETAINER REPLACEMENT

Your pump's retainer is locked into place by one of the two following methods. Determine which method was used on your pump's retainer, then follow the appropriate steps to remove the old and install and stake the new.

Method 1 - Retainer shows no sign of stake marks

1. This retainer has been locked in place with a Loctite product. To replace it, a moderate amount of heat needs to be applied to the cylinder nut (in the area of the retainer) to soften the existing Loctite allowing it to be removed.
2. Install the new retainer into the cylinder nut and torque to 80/100 in. lbs. **Note: Do not use a Loctite product this time but stake the new retainer in place according to instructions in Step 3.**
3. To lock retainer into place, use a center punch positioned in the seam between the retainer and the cylinder nut and stake the new retainer in two places approximately 180° apart.

Method 2 - Retainer has two stake marks in the seam between the retainer and the cylinder nut

1. For replacement of this retainer, the stake marks must be removed. Using a 1/8" or larger diameter drill bit, remove the existing stakes by drilling a short distance into the stake marks. Remove the retainer.
2. Install the new retainer into the cylinder nut and torque to 80/100 in. lbs.
3. To lock retainer into place, use a center punch positioned in the seam between the retainer and the cylinder nut and stake the new retainer in two places approximately 180° apart.

NOTE: Do not stake in the old stake marks.

