

PELL CABLE CUTTER COMPANY

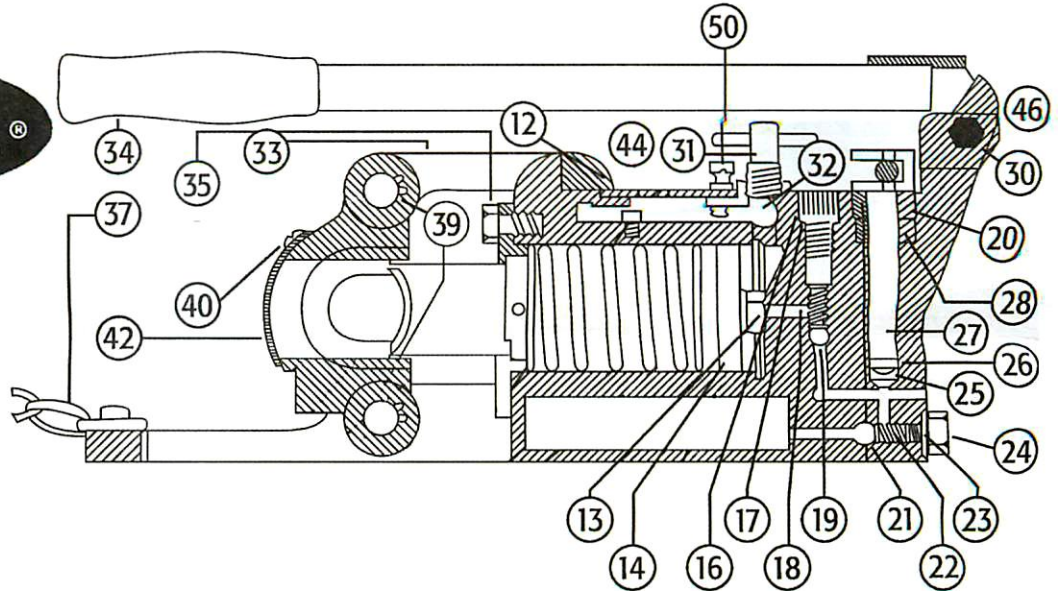

MODELS
 W075
 P1125
 C1750
 Assembly Drawing



HYDRASHEAR REPLACEMENT PARTS

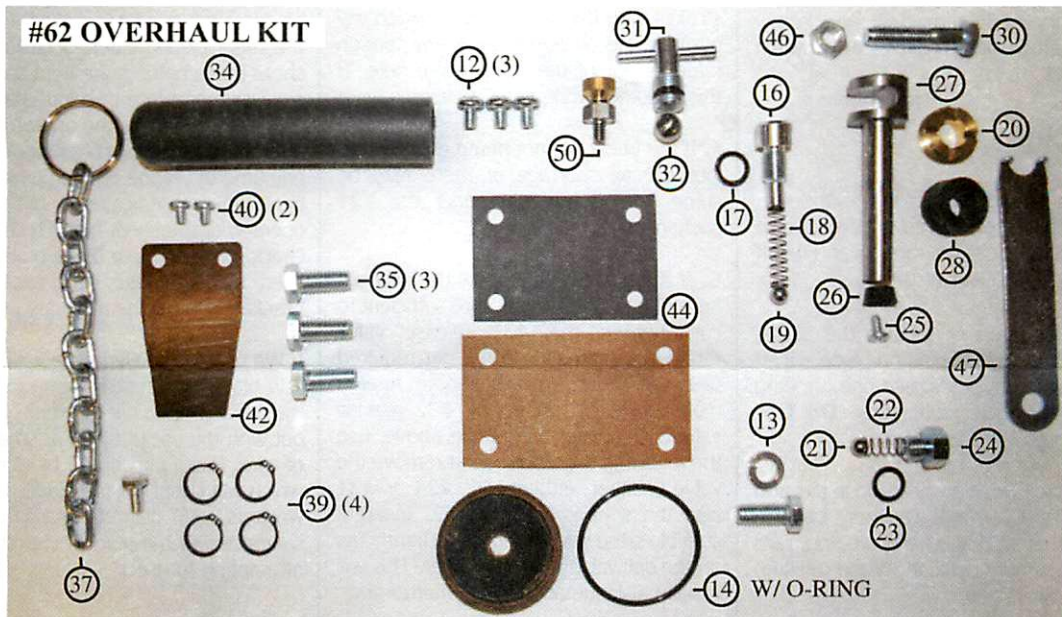

#62 OVERHAUL KIT INCLUDES:

- | | | |
|-----------------------------------|--|---------------------------|
| 12. Cover Plate Screws (3) | 23. Suction Valve Gasket | 35. Ram Collar Screws (3) |
| 13. Ram Retainer Screw w/washer | 24. Suction Valve Plug | 37. Bail w/Bolt |
| 14. Ram Cup Leather & O-Ring | 25. Plunger Packing Screw | 39. Snap Rings (4) |
| 17. Check Valve Plug | 26. Plunger End Packing | 40. Guard Screws |
| 18. Check Valve Gasket 1-3/8 Long | 27. Plunger | 42. Guard Plate |
| 19. Ball Check Valve 5/16" dia. | 28. Plunger Packing Set 4 pcs. | 44. Cover Gasket |
| 20. Packing Nut | 31. Release Valve Retainer with o-ring | 46. Lock Nut |
| 21. Ball Suction Valve 5/16" dia. | 32. Release Valve 1/2" dia. | 47. Packing Nut Wrench |
| 22. Suction Valve Spring 11/16" | 34. Handle Grip | 50. Air Vent Valve |

PELL HYDRASHEAR

Operating and Service Instructions

Important: This Hydrashear is filled with oil and is ready for operation. When replacing oil, use any light petroleum base oil such as SAE 10 or equivalent.

DO NOT USE HYDRAULIC BRAKE FLUID OR COMPOUNDED OILS

Operating:

1. Open #31 release valve so blade is at full retracted position.

2. Raise #33 latch and open #43 shear blade holder. Place wire rope in shear blade holder and close latch. If latch will not close, blade is not aligned to shear blade or guides or the material to be cut is oversized.

3. Tighten #31 release valve and begin working pump with short firm strokes. Release valve must be tight. Use extension handle or if necessary, tap with hammer. Otherwise, oil will bypass this valve and cause leakage.

4. After completing cut, open release valve and blade will return to retracted position.

5. If blade does not retract with latch closed, pry back with claw bar, screw driver or other tool. **Do Not Pound with Hammer!**

Servicing:

A. If ram will not retract into cylinder, it probably has been burred or damaged so that it will not clear the ram collar. File off burrs to permit clearance.

B. To re-sharpen or replace the blade, pump until #5 blade pin and blade will lift out. To sharpen blade, use fine grinding wheel or Carborundum stick. **Do Not Sharpen to Fine Edge!**

C. To add oil, wipe away all loose dirt and remove release valve retainer. Pour in sufficient oil so that when pumping, ram will to maximum position. When refilling, use only new, clean oil.

D. Should leakage of oil occur around #27 plunger, tighten #20 plunger packing nut. If leakage continues, it may indicate that #28 plunger packing or #26 plunger end packing needs replacing.

E. If the blade in your Hydrashear pulsates (that is if the blade is forced out on the down stroke of the pump handle but recedes on the up stroke) there may be some foreign material lodged under the #19 check valve.

1. Open up #31 release valve until the blade has receded, close the release valve tightly, raise pump handle about half way up and then strike it sharply downwards with the palm of your hand or a bar. Raise it and strike it 2 or 3 times more then proceed with normal pumping operation and in most cases this will flush out any foreign material.

2. Remove check valve and spring and with release valve shut, take 1 or 2 strokes with the pump handle which will pump some oil and usually any foreign material out of the check valve hole. If this does not work, see G below.

F. If the blade will not pump entirely out, look for oil shortage or there may be some foreign material under the #21 suction valve.

G. If the blade will pump all the way out but will not build up pressure sufficient to cut, tighten the #31 release valve retainer. If you still do not get required pressure, there may be some foreign material lodged under the #32 release valve. To correct any of the above, use the following procedure: First remove the valve retainer, either #16, #24 or #31 also the springs #18 or #22. Insert a suitable sized punch or rod and lightly tap on the ball valve with a hammer. This will usually dislodge any foreign matter and

reset valve. If this does not work, it may be necessary to remove all oil and flush the Hydrashear thoroughly then refill with clean oil. Should it become necessary to drain and refill, remove the nameplate cover and fill with oil until the cylinder is covered. Push the #32 release valve out of position and top the Hydrashear so the oil will run into the release valve hole. Hold in this position until the system has become entirely filled with oil which will be indicated by the disappearance of any air bubbles. While in this position, it may be desirable to take 2-3 strokes on the pump handle to further force any air out of the system.

H. If you feel you are having excessive blade breakage, carefully examine your shear blades. If the shear blades are cracked or broken, they permit small pieces of steel to wedge in between the blade and shear blades and excessive blade breakage will occur. If the shear blades are broken or cracked, examine the shear blade holder. Occasionally, shear blade holders are bent due to excessive pressure developed and especially so where the operator has attempted to cut solid bar stock. If at any time the hinge or latch pins are bent, which is indicated by difficult opening of the shear blade holder, check for bent shear blade holder. If the shear blade holder is bent, excessive breakage of the shear blades will occur.

I. We use, in the Hydrashear, a hollow split blade pin. In attempting to remove the blade pin, do not attempt to drive it out with the use of a nail or small piece of wire. Use a punch or a blunt object which will closely fit the blade pin hold which is 3/16" diameter. A nail is satisfactory if the point is cut off before attempting to use.

IMPORTANT

DO NOT continue to pump after wire has been cut through
DO NOT continue to operate the Hydrashear if it requires excessive effort. The Hydrashear will cut any wire rope up to the maximum size which the shear blade holder will accept with minimum effort. Hard pumping usually indicates a dull blade. **A SHARP BLADE SELDOM BREAKS.**

DO NOT continue to use a blade that has been re-ground or re-sharpened to the extent that the back portion of the cutting edge will not enter the shear blade