

WALKER

**SERVICE
DIVISION**

Jack Parts Sheet

MODEL 93630
SERIES "B", "C" & "D"

MODEL 93632
SERIES "F", "G" & "H"

1½ TON CAPACITY
HYDRAULIC SERVICE JACK

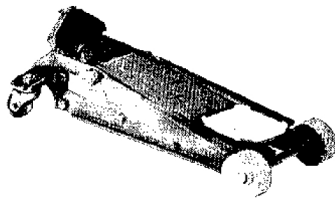

MODEL 93630
MODEL 93632

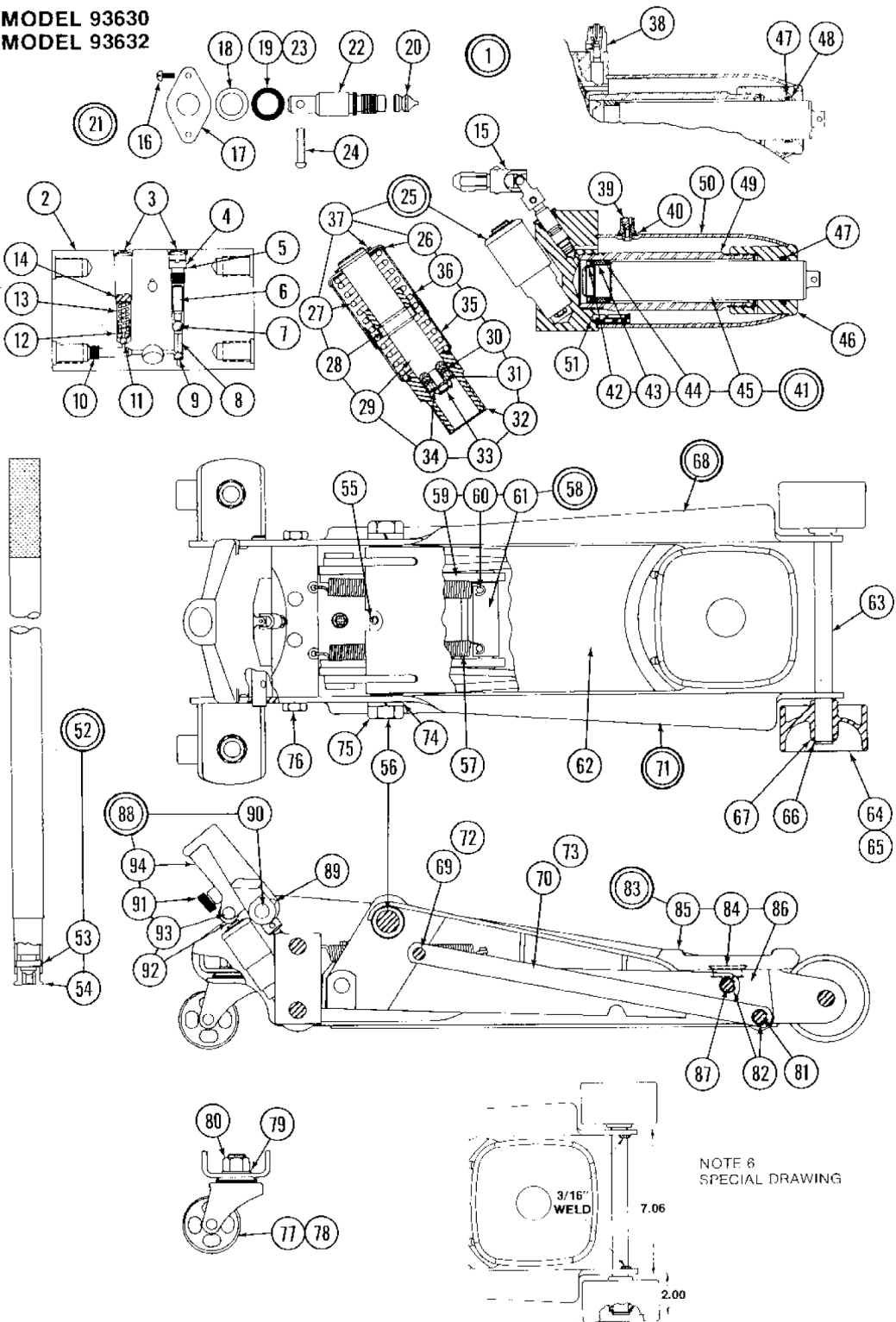

Code No.	Part No.	Description	Series	No. Req'd	Code No.	Part No.	Description	Series	No. Req'd
1	-- (1)	Hydraulic Unit Ass'y	All	1	44	224867	Back-Up Washer	All	1
2	232628(2)	Base	↓	1	45	225517	Ram	↓	1
3	201733(3)	Expansion Plug	↓	2	46	225516	Tank Nut	↓	1
4	211013	Pressure Plug	↓	1	47	221748	Quad Ring	↓	1
5	204842	Gasket-Pressure Plug	↓	1	48	221747(4)	Back-Up Washer	↓	1
6	211014	Spacer-Discharge	↓	1	49	230404	Cylinder	↓	1
7	203201	Valve-Discharge	↓	1	50	236641(5)	Oil Tank	↓	1
8	226330	Spacer-Suction	↓	1	51	221318	Screen-Suction	↓	1
9	203198	Valve-Suction	↓	1	52	226110	Handle Assembly	↓	1
10	210311	Plug	↓	1	53	212908	Groove Pin	↓	1
11	203196(6)	Safety Valve	↓	1	54	226112	Hex End	↓	1
12	226376(7)	Adapter-Safety	↓	1	55	226318	Grease Fitting	↓	1
13	226375(8)	Spring-Safety	↓	1	56	210700	Fulcrum Pin	↓	1
14	226373(9)	Adj. Nut-Safety	↓	1	57	225924	Spring	↓	2
15	228349	Universal Ass'y	↓	1	58	229048	Cross Head Ass'y	↓	1
16	222940	Screw	93630 B,C 93632 F,G	2	59	226343	Link	↓	2
17	218414	Retainer Plate	93630 B,C 93632 F,G	1	60	226335	Stud-Spring	↓	2
18	212374	Washer-Ret.	93630 B,C 93632 F,G	1	61	226344	Cross Head	↓	1
19	212375	"O" Ring	93630 B,C 93632 F,G	1	62	221705	Bellcrank Assembly	↓	1
20	218043	Release Valve	93630 B,C 93632 F,G	1	63	233339(6)	Front Axle	93632	1
21	233376	Release Stem Ass'y	93632 F,G	1	64	226614	Wheel-Front (Steel)	93632	2
22	224869	Release Stem	All	1	65	228022	Wheel-Front (Plastic)	93630	2
23	216143	"O" Ring	93630 B,C 93632 F,G	1	66	214557	Retaining Ring	All	2
24	211341	Rivet	All	1	67	204324	Washer	↓	2
25	227045	Pump Assembly	↓	1	68	231585(6)	Sideplate Ass'y - L.H.	↓	1
26	226365	Cover	↓	1	69	226342	Stud	↓	1
27	226348	Spring	D	1	70	226345	Link	↓	1
28	201142	Cross Pin	H	1	71	231584(6)	Sideplate Ass'y - R.H.	↓	1
29	226350	Piston	AR	1	72	226342	Stud (See Code #69)	↓	1
30	201828	"V" Chevrons	↓	1	73	226345	Link (See Code #70)	↓	1
31	226351	Adapter	↓	1	74	201478	Lockwasher	↓	2
32	226339	Cylinder	↓	1	75	203311	Nut	↓	2
33	224725	Nut	↓	1	76	231589	Shoulder Bolt	93632	4
34	204733	Washer	↓	1	77	231583	Caster (Steel)	93630	2
35	226357	Lower Sleeve	↓	1	78	231601	Caster (Plastic)	All	2
36	226356	Top Sleeve	↓	1	79	201779	Washer	All	2
37	201803	Retainer	↓	1	80	219451	Nut	↓	2
38	227095	Filler/Vent Plug	93630 B 93632 F	1	81	226349	Pin-Cap Housing to Link	↓	1
39	231316	Filler/Vent Plug	93630 C,D 93632 G,H	1	82	201801	Retaining Ring	↓	4
40	200003	Gasket-Filler Plug	93630 C,D 93632 G,H	1	83	221701	Cap Housing Assembly	↓	1
41	225518	Ram Assembly	93632 G,H	1	84	226355	Stud	↓	1
42	227919	"U" Cup	↓	1	85	221702	Cap	↓	1
43	224760	Heel Plate	↓	1	86	226491	Housing	↓	1
					87	221703	Pin-Cap Hsg. to Bellcrank	↓	1
					88	230486	Handle Socket Ass'y	↓	1
					89	202359	Rivet	↓	2
					90	226336	Pin	↓	2
					91	226341	Thumbscrew	↓	1
					92	226334	Roller	↓	1
					93	213915	Pin-Roller	↓	1
					94	230400	Handle Socket	↓	1

- (1) Contact Factory or nearest Authorized Service Depot when complete unit assembly is needed.
- (2) This base does not provide for Filler/Vent opening as in early production. When used on early design, it will require use of 231641 Oil Tank and 231316 Filler/Vent plug. Also add 233376 Release Stem Assembly, as release gland cover is removed on late production series.
- (3) Repairs not recommended without required special tools and test equipment.
- (4) Not used on late production.
- (5) Provides hole for Filler/Vent screw on late production. Should be sealed with 212540 Filler Screw and 200003 Gasket when used on early production unit with Filler/Vent in base.
- (6) Positive positioning of 233339 Front Axle to side plate assembly is critical. When replacement of these parts is necessary, refer to special drawing giving dimensions and welding instructions.

ORDER BY PART NUMBER, **NOT** CODE NUMBER
SEE BACK PAGE FOR COMPLETE NUMERICAL LISTING