



# Portable Air Jack

## Operating Instructions & Parts Manual

Model Number  
HW93737A

Capacity  
10 Ton



**Made in the  
U.S.A.**

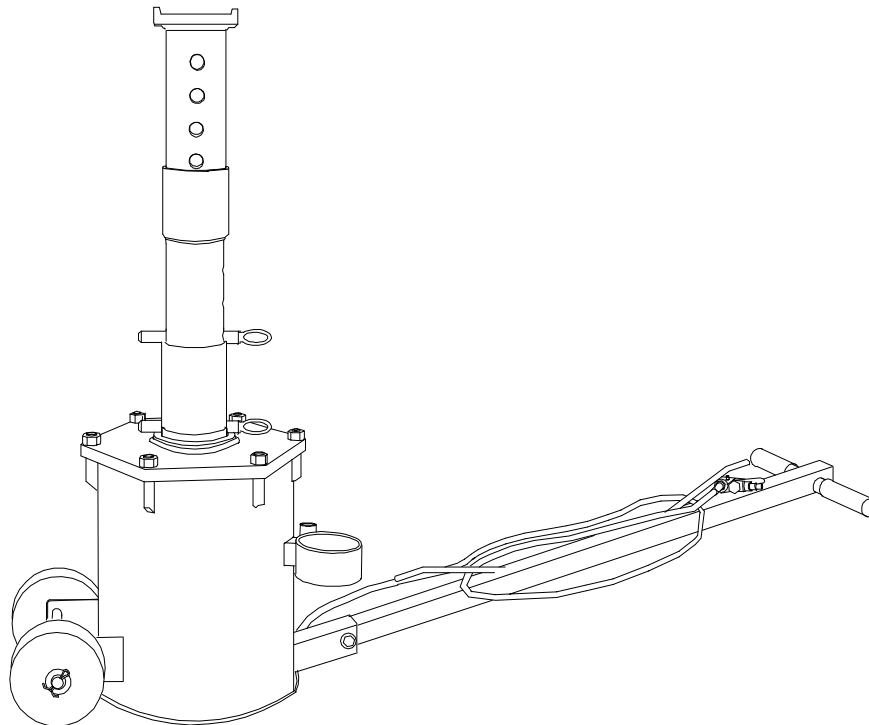

This is the safety alert symbol. It is used to alert you to potential personal injury hazards. Obey all safety messages that follow this symbol to avoid possible injury or death.

SFA Companies  
10939 N. Pomona Ave. Kansas City, MO 64153  
816-891-6390 [customerservices@heinwerner-automotive.com](mailto:customerservices@heinwerner-automotive.com)

**Read this manual and follow all the Safety Rules and Operating Instructions before using this product.**

## SAFETY and GENERAL INFORMATION

**Save these instructions.** For your safety *read, understand, and follow* the information provided with and on this jack. The owner and operator of this equipment shall have an understanding of this jack and safe operating procedures before attempting to use. The owner and operator shall be aware that use and repair of this product may require special skills and knowledge. Instructions and safety information shall be conveyed in the operator's native language before use of this jack is authorized. If any doubt exists as to the safe and proper use of this jack, remove from service immediately.

**Inspect before each use.** Do not use if broken, bent, cracked, or damaged parts (including labels) are noted. Any jack that appears damaged in any way, operates abnormally or is missing parts, shall be removed from service immediately and the manufacturer notified. If you suspect that the jack was subjected to a shock load (a load dropped suddenly, unexpectedly upon it), immediately discontinue use until the jack has been checked by a factory authorized service center (contact distributor or manufacturer for list of Authorized Service Centers). It is recommended that an annual inspection be done by qualified personnel. Replace worn or damaged parts with Hein-Werner Authorized Replacement Parts only. Labels and owner's manuals are available from manufacturer.

## PRODUCT DESCRIPTION

Hein-Werner Portable Air Jack is designed to lift and support rated capacity loads. **Intended use:** To lift **one wheel** or **one axle** of a vehicle for the purpose of service and/or repair of vehicle components. Use this jack in pairs when lifting an entire end of a vehicle. Check with vehicle owner's manual for proper lift points. Use one pair per vehicle.



Rated Capacity of this device is intended to be used as a reference of the working load that this stand is capable of sustaining. the rated capacity is not increased when used in multiples.



*Do not use for any purpose other than those uses outlined above!*

**DO NOT** use this jack around corrosive materials such as chlorides, which is commonly used by road crews to melt snow and ice. Water and slush from vehicles exposed to chlorides may drip into the cylinder of the jack and will severely and permanently damage the inside of cylinder and cause air leaks which adversely affect the lifting performance of this jack.

## SPECIFICATIONS

Model	Capacity	Starting Height	Max. Lift Height	Power Travel	Jack Size ( L x W x H )	Air Pressure for Rated Capacity	Weight
HW93737A	10 Ton	17 3/4" to 40"	51 1/2"	11 1/2"	22" x 12" x 17"	200 psi	165 lb.

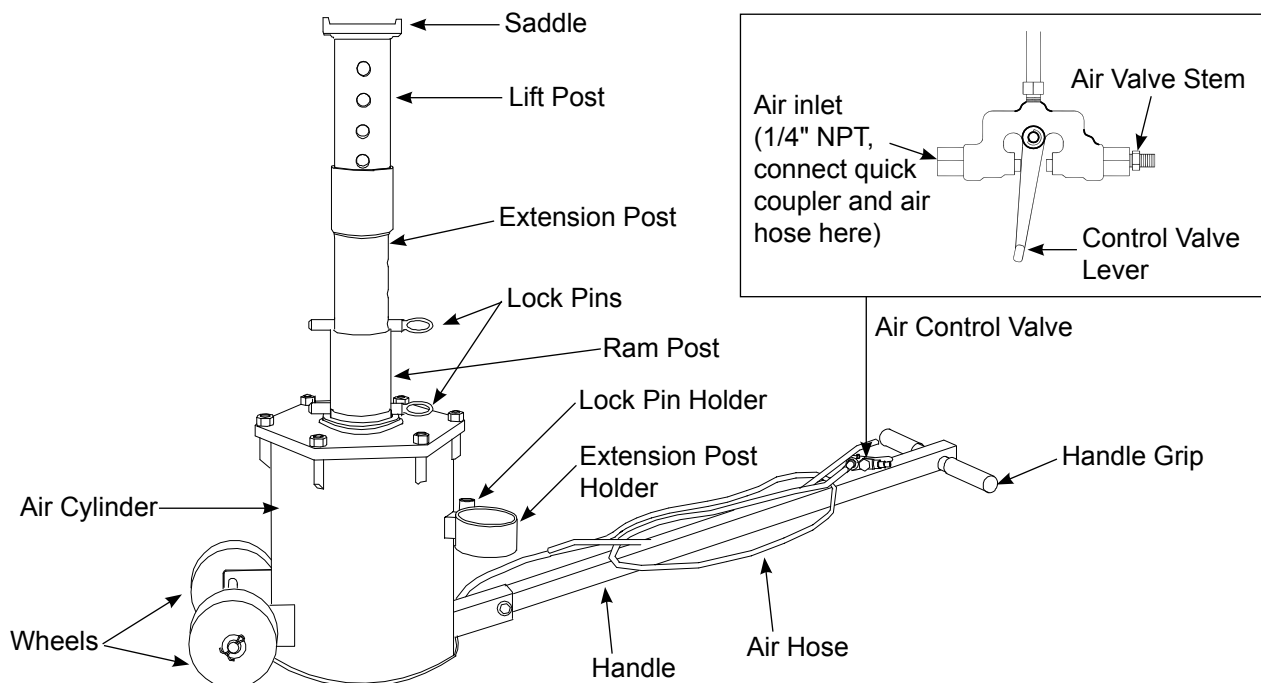

Figure 1 - Portable Air Jack Components

## **WARNING**

- **Study, understand, and follow** all printed materials provided with/on this product before use.
- **Do not** exceed rated capacity. Rated capacity does NOT increase with the use of multiple jacks.
- Use only on hard, level surfaces capable of supporting rated capacity loads.
- Place load on center of lifting saddle only.
- Do not use adapters or accessories that are not provided initially.
- Never use more than one extension with this unit. Using more than one extension causes the load to be lifted beyond the maximum designed safety lifting height, which could cause loss of load.
- Use the jack in pairs when lifting an entire end of a vehicle; use separately when lifting one side of a vehicle.
- Lift only on areas of the vehicle as specified by the vehicle manufacturer.
- After lifting, never work on, under or around a load until the lifting post of jack is properly pinned and the air is exhausted. If the air is not exhausted and the jack is not properly pinned, the jack may rise or drop suddenly when a heavy object is removed from or placed on the vehicle.
- Do not attempt to raise a partially filled tanker or transport containing an unrestrained load. A sudden load shift can occur causing dangerous tilting or toppling of the vehicle.
- Do not move or dolly loads with this device.
- No alterations shall be made to this product.
- Failure to heed these markings may result in personal injury and/or property damage.

## **ADVERTENCIA**

- Leer, comprender, y seguir las instrucciones antes de utilizar el aparato.
- El manual de instrucciones y la información de seguridad deben estar comunicado en lengua del operador antes del uso.
- No seguir estas indicaciones puede causar daños personales o materiales.

## **PREPARATION**

### **Before Use**

1. Verify that the product and application are compatible, if in doubt call Hein-Werner technical service.
2. Before use, read the operator's manual completely and familiarize yourself thoroughly with the product, its components and recognize the potential hazards associated with its use.

### **Assemble handle**

Attached handle to the handle bracket with bolt and nut provided. Refer to Figures in the manual for components location. Know your jack and how it operates before attempting to use.

### **Prepare air system**

**Note:** Air source must supply 200 psi maximum to each jack operated.

1. Remove plastic plug on air stem and connect 1/4" NPT quick coupler of your choice to the air supply inlet.
2. Pour a teaspoon of good quality air tool lubricant into air supply inlet of the air control valve.
3. Use of an inline air dryer is required.

### **Check the jack**

1. Roll the jack to ensure that it rolls freely and smoothly.
2. Raise and lower the unloaded saddle throughout the lift range to ensure proper operation before placing any load on the product. Push the control valve lever toward air supply inlet to raise; toward air valve stem to release the air.
3. Replace worn or damaged parts and assemblies with Hein-Werner Replacement Parts only. (See Replacement Parts Section). Lubricate as instructed in Maintenance Section.

## OPERATION

### Lifting



*Only attachments and/or adapters supplied by the manufacturer shall be used. Lift only on areas of the vehicle as specified by the vehicle manufacturer.*

1. Follow the vehicle manufacturer's recommended guidelines for lifting.
2. Position vehicle on hard level surface with parking brakes "ON". Chock wheels at opposite end. When lifting trailers, lower landing gear.
3. Connect air control valve with a quick coupler, then attach to air supply of 200 psi maximum. The unit is now ready to use.

**Note:** Actuation of the air control valve will raise and lower the lift post.

4. Position the unit under the lift point of the vehicle.
5. Push the air control valve lever toward air supply input to raise the lift post until it contacts lift point. Continue to hold until it reaches desired height.

### **Operating the jacks simultaneously**

These jacks are often used in pairs, simultaneously operating both units' air control valves from one air line offers advantages (refer to figure 2). Follow the proper instruction on the use of the jacks simultaneously from one air line.

- a. Raise the lift post or extension post manually on each unit to engage the manufacturer's recommended lift point.
- b. Keep both lift post/extension post at equal heights and insert the lock pin in the nearest through hole in the lift post/extension post so that the lock pin fully engages both sides of the head plate.

**Note:** This position may not fully engage the lift point on the vehicle until the unit is pressurized to lift the load. If the lift post is not fully engaged with the lift point, slowly apply air pressure until the lift post engages the lift points on the vehicle.

- c. *Before lifting*, ascertain that the lift post saddle is positioned such that the lift point is cradled and captured on both sides by the saddle ears on each side of the lift post.
  - d. Apply pressure equally.
6. Once the proper height has been achieved, insert the other lock pin through the hole in the ram post such that the lock pin will fully engage both sides of the head plate when lowered.
  7. Before lowering the unit(s) so that the pins fully engage the head plate, make sure that the vehicle is level.
  8. Slowly release the air pressure and make sure the lock pin engages fully into both sides of the head plate slot.
  9. Ensure the vehicle is level and stable before exhausting the air pressure.
  10. Fully discharge the air pressure from the jacks.
  11. Before working around the lifted vehicle, ensure the vehicle is level and stable between the jacks.



## WARNING

- If using only one jack to do the lifting, be sure that the jack is positioned according to the manufacturers suggested lifting point and that the load is balanced on the stand side to side.
- Ensure the load is level and stable during and after lifting when lifting with only one jack. Loads that are not balanced can result in the tipping of the jack which can result in personal and/or property damage.
- **Do not connect two jacks to one control valve.** Operating the jacks in this way can cause of loss of control during raising and lower the vehicle.
- Failure to heed these markings may result in property damage, personal injury and/or death.

## Lowering



Be sure all tools and personnel are clear before lowering load. **Maintain control** of the rate of speed at which the load lowers at all times!

1. Push the air valve lever towards air input to apply air pressure slowly with lock pin still engaged.
2. Ensure the vehicle is still stable and level before removing lock pin. Then, *carefully* remove the lock pin.
3. Push the air valve lever slowly towards air valve stem to exhaust air pressure, vehicle will gradually lower.
4. Discharge the air pressure from the jack fully once the vehicle is on the ground.
5. Remove the jack from under the vehicle and place it away from the work area.
6. Ensure the saddle is fully lowered and keep extension post in the extension post holder.

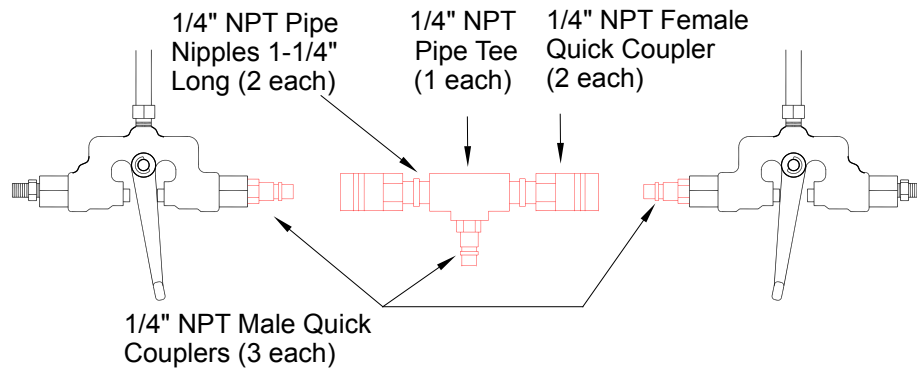

Figure 2 - Illustration for assembling the connectors

## MAINTENANCE

Inspections should be made before each use of jack, checking for abnormal conditions. Regular inspections should be made weekly for daily use and monthly for intermittent use.

1. Inspect air hose for leaks or kinks. Replace if necessary.
2. Air control valve should operate freely. Wheels should rotate freely.
3. The ram should extend and retract smoothly throughout its full range.
4. A periodic coating of light lubricating oil to all rotating and sliding portions of the jack will help to prevent rust and assure that the wheels move freely.
5. Lower the saddle to its lowest position when not in use.
6. When jack is not in use, tip it forward until it rests on the wheels and use extra support to hold the jack as shown in figure 3. This allows trapped water to drain from inside the cylinder.

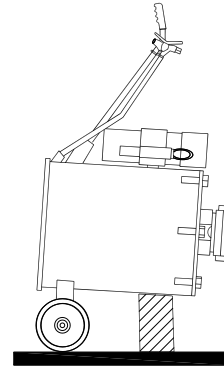

Figure 3.

## TROUBLESHOOTING

Symptom	Possible Causes	Corrective Action
Jack will not lift load	<ul style="list-style-type: none"> <li>• Inadequate air supply</li> <li>• Overload condition</li> <li>• Air line leaks</li> </ul>	<ul style="list-style-type: none"> <li>• Ensure adequate air supply</li> <li>• Use larger capacity jack</li> <li>• Locate and seal leaks</li> </ul>
Jack will not hold load	<ul style="list-style-type: none"> <li>• Locking pin not engaged</li> </ul>	<ul style="list-style-type: none"> <li>• Engage locking pin</li> </ul>
Jack is very bouncy	<ul style="list-style-type: none"> <li>• Cylinder might need lubrication</li> </ul>	<ul style="list-style-type: none"> <li>• Apply #630-AAA LUBRIPLATE to cylinder wall</li> </ul>

# REPLACEMENT PARTS

Not all components of the jack are replacement items, but are illustrated as a convenient reference of location and position in the assembly sequence. When ordering parts, give model number, part number and parts description. Call or write for current pricing: Hein-Werner Customer Support, 10939 N. Pomona Ave. Kansas City, MO 64153. Phone: (816)891-6390; E-mail: customerservices@heinwerner-automotive.com

Item	Part#	Description	Qty.
1	737-002-001	Cylinder Assy.	1
2	737-002-002	Wheel	2
3	737-002-003	Cotter Pin	2
4	737-002-004	Bushing	2
5	737-002-005	Washer	2
6	737-002-006	Ram	1
7	737-002-007	Saddle	1
8	737-002-008	Ring	1
9	737-002-009	Pin	2
10	737-002-010	Seal	1
11	737-002-011	Washer	1

Item	Part#	Description	Qty.
12	737-002-012	Bolt	1
13	737-002-013	Extension Post	1
14	737-002-014	Nut	6
15	737-002-015	Cylinder Cap	1
16	737-002-016	Grip	2
17	737-002-017	Handle	1
18	737-002-018	Nut	1
19	737-002-019	Air Hose	1
20	737-002-020	Valve	1
21	737-002-021	Bolt	1
22	737-002-022	Ram Wear Guide	1

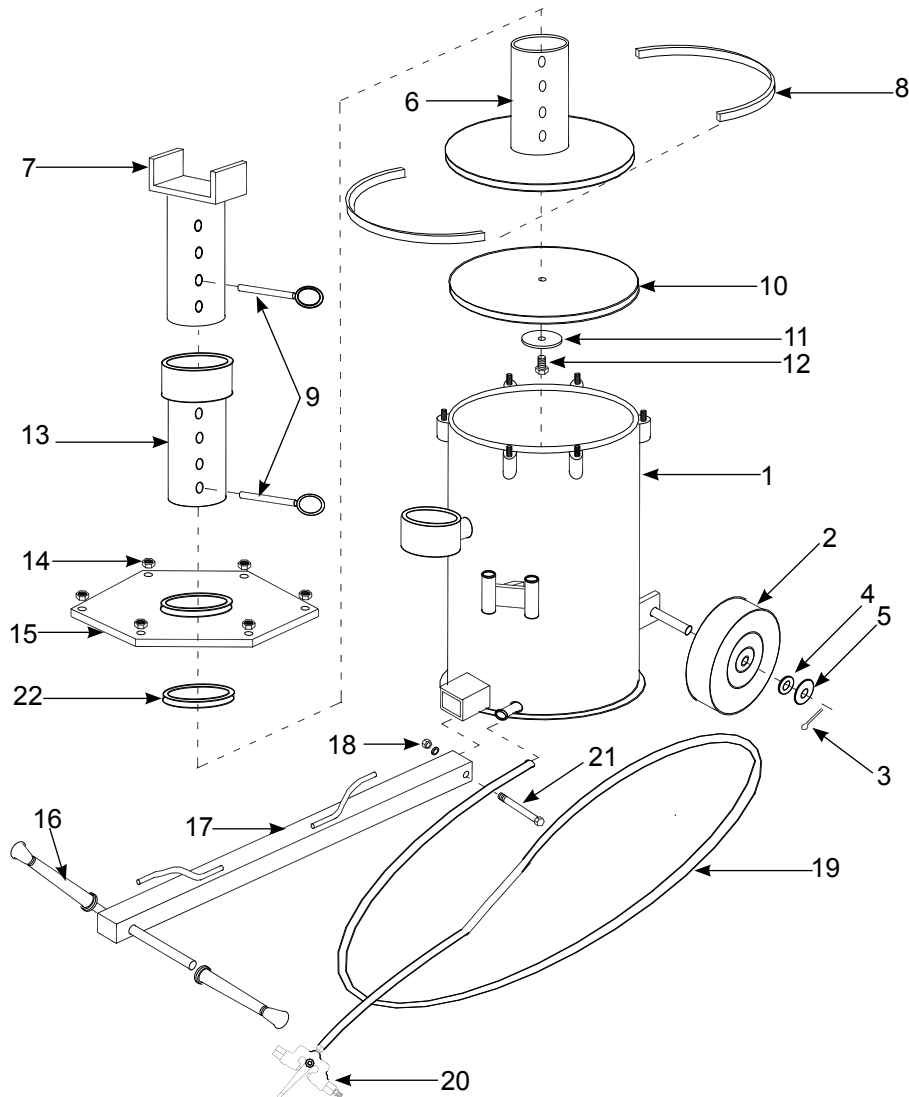

Figure 4 - Parts Illustration for Model HW93737A



## **TWO YEARS LIMITED WARRANTY**

For a period of two (2) years from date of purchase, SFA Companies will repair or replace, at its option, without charge, any of its products which fails due to a defect in material or workmanship under normal usage. This limited warranty is a consumer's exclusive remedy.

Performance of any obligation under this warranty may be obtained by returning the warranted product, freight prepaid, to SFA Companies Warranty Service Department, 10939 N. Pomona Ave., Kansas City, MO 64153. Except where such limitations and exclusions are specifically prohibited by applicable law:

- (1) THE CONSUMER'S SOLE AND EXCLUSIVE REMEDY SHALL BE THE REPAIR OR REPLACEMENT OF DEFECTIVE PRODUCTS AS DESCRIBED ABOVE
- (2) SFA COMPANIES SHALL NOT BE LIABLE FOR ANY CONSEQUENTIAL OR INCIDENTAL DAMAGE OR LOSS WHATSOEVER.
- (3) ANY IMPLIED WARRANTIES, INCLUDING WITHOUT LIMITATION THE IMPLIED WARRANTIES OF MERCHANTABILITY AND FITNESS FOR A PARTICULAR PURPOSE, SHALL BE LIMITED TO TWO YEARS, OTHERWISE THE REPAIR, REPLACEMENT OR REFUND AS PROVIDED UNDER THIS EXPRESS LIMITED WARRANTY IS THE EXCLUSIVE REMEDY OF THE CONSUMER, AND IS PROVIDED IN LIEU OF ALL OTHER WARRANTIES, EXPRESS OR IMPLIED.
- (4) ANY MODIFICATION, ALTERATION, ABUSE, UNAUTHORIZED SERVICE OR ORNAMENTAL DESIGN VOIDS THIS WARRANTY AND IS NOT COVERED BY THIS WARRANTY.

Some states do not allow limitations on how long an implied warranty lasts, so the above limitation may not apply to you. Some states do not allow the exclusion or limitation of incidental or consequential damages, so the above limitation or exclusion may not apply to you. This warranty gives you specific legal rights, and you may also have other rights which vary from state to state.