



## INSTRUCTION MANUAL/REPAIR PARTS LIST

HAND JACK MODELS H68026, H68027, H68028

### **⚠ WARNING**

1. THIS IS A LIFTING DEVICE ONLY. THE LOAD MUST BE SUPPORTED IMMEDIATELY BY OTHER APPROPRIATE MEANS.
2. DO NOT EXCEED RATED CAPACITY.
3. USE ONLY ON HARD LEVEL SURFACE CAPABLE OF SUSTAINING LOAD.
4. CENTER LOAD ON SADDLE.
5. IT IS YOUR RESPONSIBILITY TO KEEP WARNING DECALS LEGIBLE AND INTACT. REPLACE DECALS MAY BE OBTAINED FROM THE FACTORY.
6. STUDY, UNDERSTAND, AND FOLLOW ALL INSTRUCTIONS PROVIDED WITH THIS JACK PRIOR TO OPERATION.
7. FAILURE TO HEED THESE WARNINGS MAY RESULT IN LOSS OF LOAD, DAMAGE TO JACK, OR FAILURE RESULTING IN PROPERTY DAMAGE, PERSONAL, OR FATAL INJURY.

### OWNER'S RESPONSIBILITY

**Operation.** The owner and/or operator shall have an understanding of these operating instructions and warnings before operating the jack. Warning information shall be emphasized and understood. If the user is not fluent in english, the instructions and warnings shall be read to and discussed with the operator in the operator's native language by the purchaser/owner, making sure that the operator comprehends its contents.

**Maintenance.** The jack shall be maintained in accordance with instructions listed under "Maintenance."

#### Inspection

1. Visual inspection shall be made before each use of the jack, checking for leaking hydraulic fluid, and damaged, loose or missing parts.
2. Each jack, shall be inspected by an authorized service center immediately, if subjected to an abnormal load or shock.
3. Owners and/or users should be aware that repair of this equipment may require specialized knowledge and facilities. It is recommended that an annual inspection of the jack be made by an authorized service center and that any defective parts, decals or warning labels be replaced with genuine factory parts. A list of authorized service centers is available upon request.

**Damaged Jacks.** Any jack which appears to be damaged in any way, is found to be badly worn, or operates abnormally SHALL BE REMOVED FROM SERVICE until necessary repairs are made by an authorized service center.

### INSTRUCTIONS BEFORE USE

1. **Check oil level.** With the jack in an upright position and the ram completely retracted, open release valve by turning release assembly counterclockwise. Remove filler plug - the oil should be just up to the hole. Fill if necessary with clean hydraulic jack oil. Never use motor oil or brake fluid.
2. **Lubricate internal components.** With release valve open, pump handle six full strokes to assure proper internal lubrication.
3. **Bleed hydraulic system.** During transit hydraulic jacks may become air-bound causing spongy ram action. To bleed the hydraulic system - close the release valve by turning clockwise. Insert handle in socket and pump jack to full height. Open the release valve, invert the jack and force the ram to retract.

### OPERATING INSTRUCTIONS

1. **Lifting** - Turn release assembly clockwise to close release valve. Position jack where desired and adjust extension screw if necessary, being sure that load is centered. Insert handle in socket and pump handle until load is desired height.

### **⚠ WARNING**

**USE JACK FOR LIFTING ONLY. LOAD MUST BE SUPPORTED IMMEDIATELY BY OTHER APPROPRIATE MEANS.**

2. **Lowering** - Open release valve by slowly turning release assembly counterclockwise.

### MAINTENANCE

1. When jack is not in use, keep the ram and extension screw completely retracted and the release valve closed.
2. Keep the jack clean. Occasionally lubricate the handle socket pivot point, extension screw, and release screw thread.
3. Frequently check oil level. For procedure see "Instructions Before Use."

I11H68026000B0

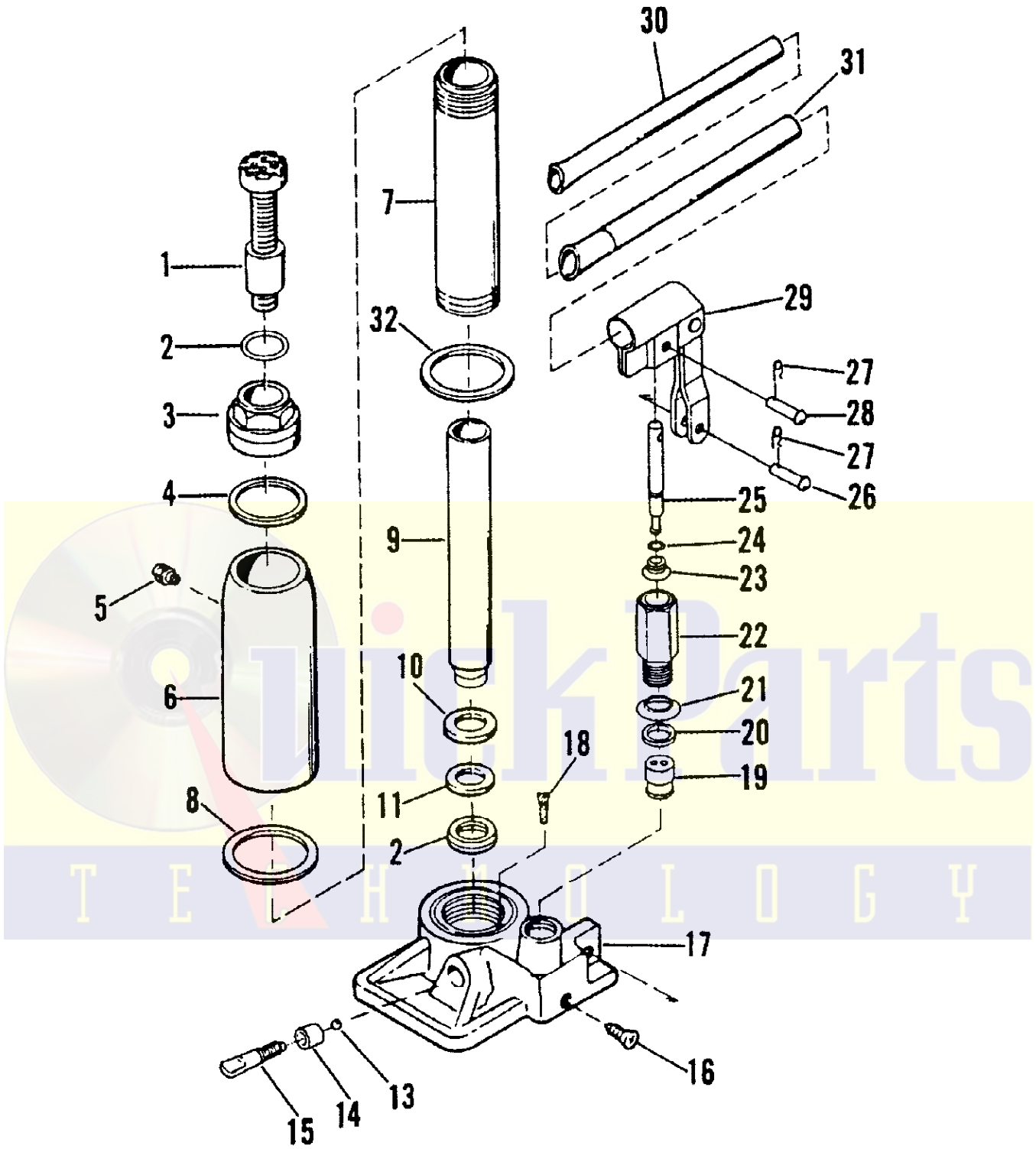

**Winner service and service parts  
are available only through your  
local authorized service center**

## PARTS LIST - HAND JACK

No.	Parts Description	2 Ton H68026	4 Ton H68027	6 Ton H68028
1	Ext. Screw Assembly	N/A	N/A	N/A
2	O-Ring (Top Nut)	_____*	_____*	_____*
3	Top Nut	N/A	N/A	N/A
4	Gasket (Upper)	_____*	_____*	_____*
5	Filler Plug	N/A	N/A	N/A
6	Reservoir	N/A	N/A	N/A
7	Ram Cylinder	_____*	_____*	_____*
8	Gasket (Lower)	N/A	N/A	N/A
9	Ram Plunger Assembly	N/A	N/A	N/A
10	Ram Bearing	_____*	_____*	_____*
11	Back-Up Washer	_____*	_____*	_____*
12	U-Cup (Ram)	_____*	_____*	_____*
13	Ball 1/4	_____*	_____*	_____*
14	Packing	H6952100	H6952100	H6952100
15	Release Screw	N/A	N/A	N/A
16	Valve Plug	N/A	N/A	N/A
17	Base	H6810000	H6810000	H6810000
18	Filter	_____*	_____*	_____*
19	Hydraulic Cartridge	_____*	_____*	_____*
20	Packing (Pump)	H6951600	H6951600	H6951600
21	Washer	H6951500	H6951500	H6951500
22	Pump Cylinder	_____*	_____*	_____*
23	U-Cup (Piston)	_____*	_____*	_____*
24	O-Ring (Piston)	H6950800	H6950800	H6950800
25	Pump Piston	H6951000	H6951000	H6951000
26	Pin (Links)	H6951200	H6951200	H6951200
27	Retainer Rings (2)	H6964300	H6964300	H6964300
28	Pin - Handle Socket	H6950600	H6950600	H6950600
29	Handle Socket Assembly	H6953100	H6953100	H6953100
30	Handle (Upper)	H6953200	H6953200	H6953200
31	Handle (Lower)	N/A	N/A	_____*
32	Seal Cylinder	H3128000	H3128000	H3128000
33	Warning Decal	H6954000	H6956800	H6958400
34	Product Decal	H6966100	H6966200	H6966300
	Service Kit			

\* Only available as part of a Service Kit  
 N/A = Not Available