

# HOW TO: MEASURE A U-CUP SEAL USED ON A SHOP PRESS RAM

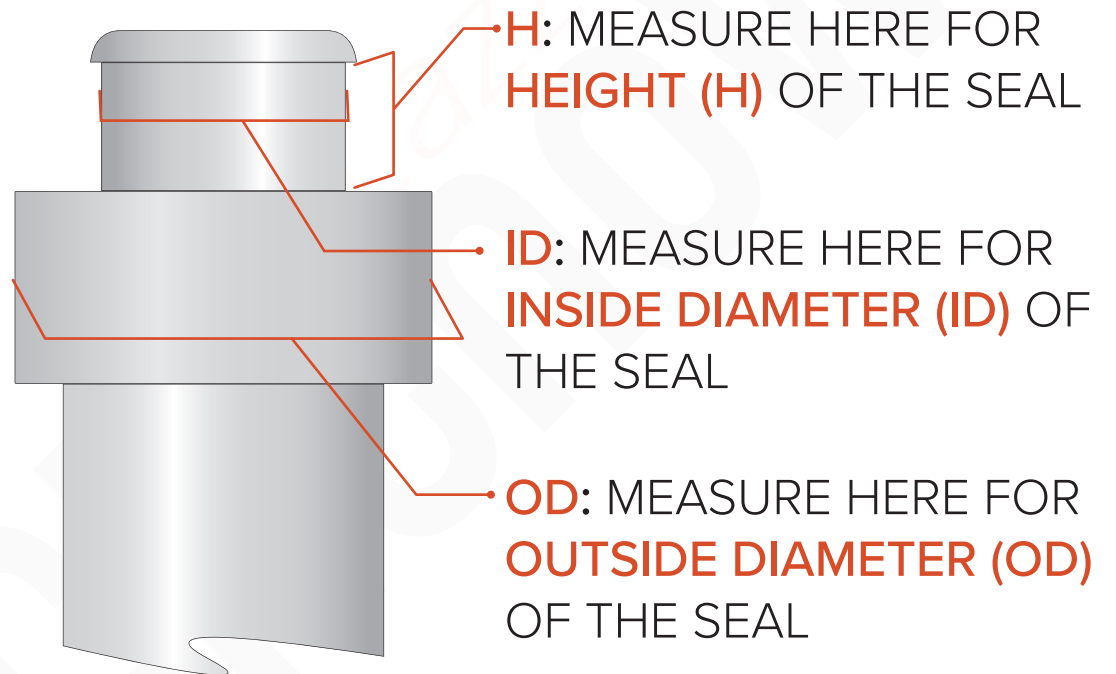

Note: For accurate measurements, please measure the metal ram, not the old seal.

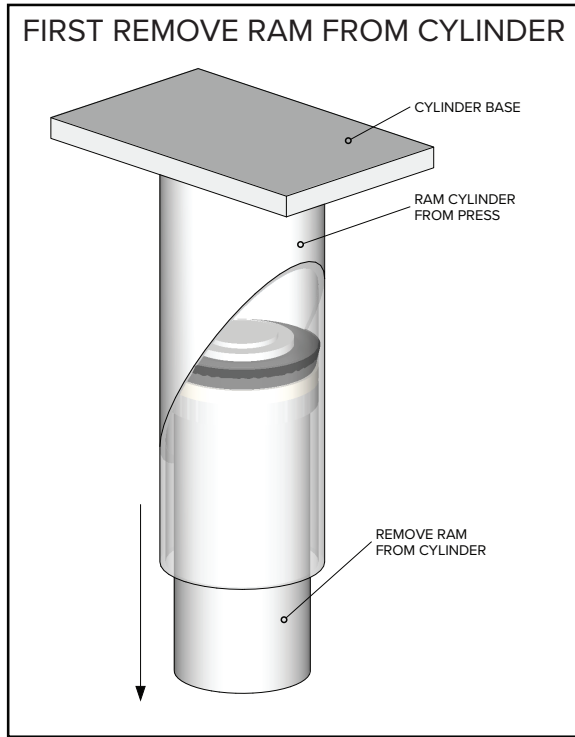
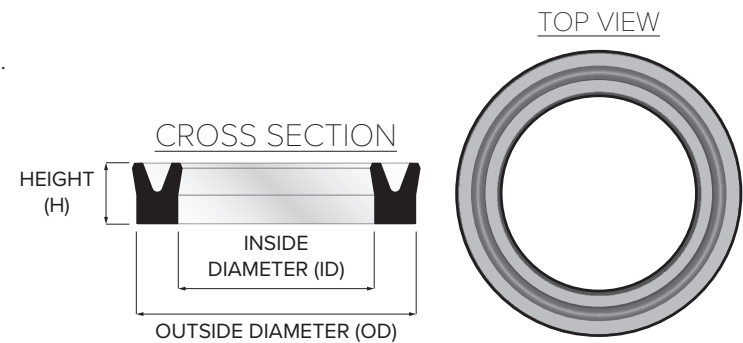

ID \_\_\_\_\_ / OD \_\_\_\_\_ / H \_\_\_\_\_

ID \_\_\_\_\_ / OD \_\_\_\_\_ / H \_\_\_\_\_

ID \_\_\_\_\_ / OD \_\_\_\_\_ / H \_\_\_\_\_