

Master Copy

repair parts

HYDRAULIC HAND JACKS

1 1/2 through 20 Ton

MODEL NUMBERS

TC-7-B	1 1/2 Ton	CB-9-E	8 Ton
BA-8.5-F	3 Ton	D-8.7G	12 Ton
AA-8.5-F	5 Ton	EA-11-E	20 Ton

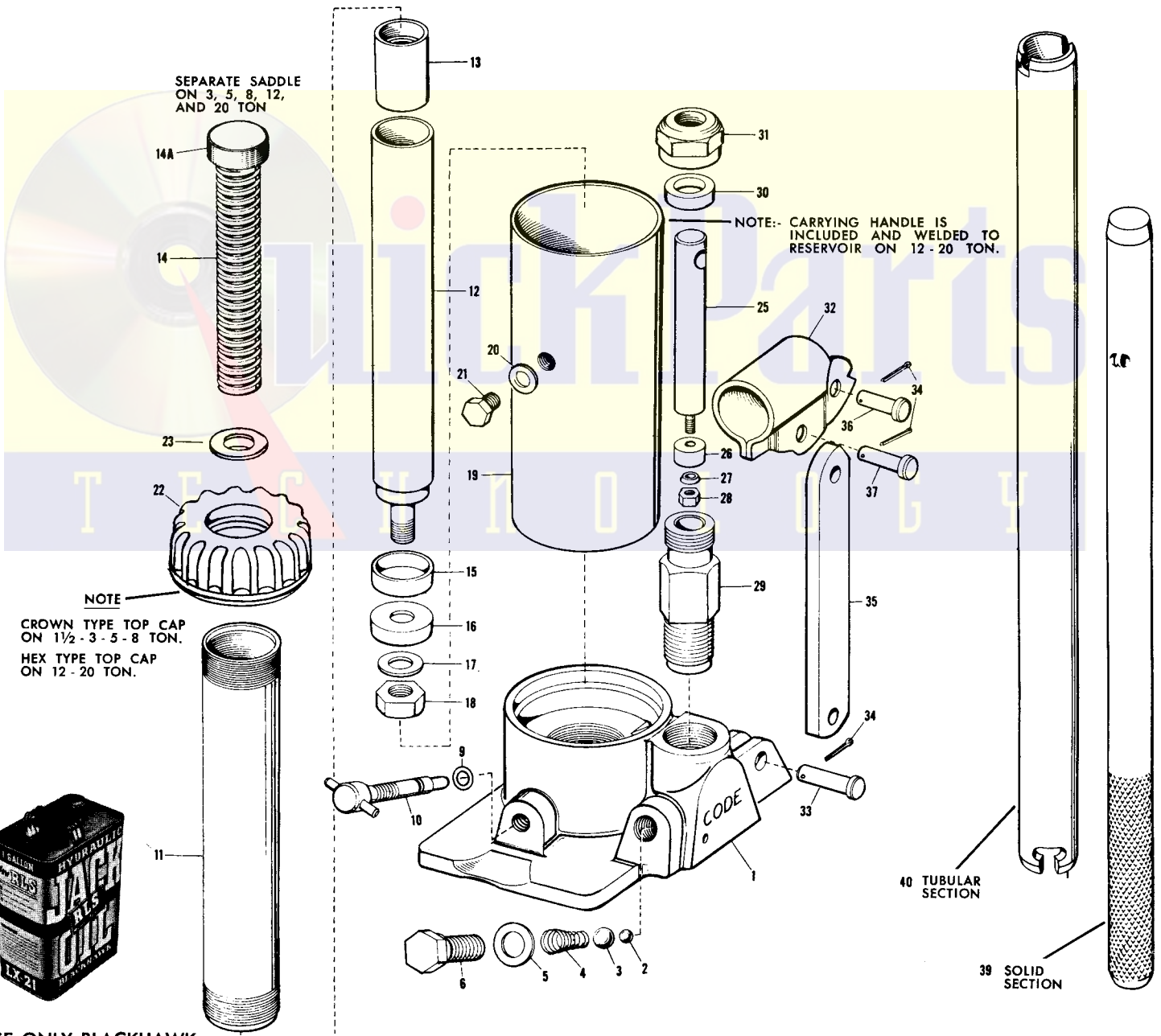

USE ONLY BLACKHAWK
LX-21 JACK OIL AND
GENUINE FACTORY PARTS.

See reverse side for part numbers for ordering purposes.

REPAIR PARTS LIST FOR HYDRAULIC HAND JACKS

Item No.	Description	TC-7-B 1½ TON	BA-8.5-F 3 TON	AA-8.5-F 5 TON	CB-9-E 8 TON	D-8.7-G 12 TON	EA-11-E 20 TON
1.	Base (Plugged)	TC7.05-1	BA85.05-4	AA85.05-5	CB9.05-4	D87.05-1	EA11.05-2
2.	*7/32" Ball	1.16	1.16	1.16	1.16	1.16	1.16
3.	*5/16" Ball	S1.16	S1.16	S1.16	S1.16	S1.16	S1.16
4.	*Outlet Valve Spring	BA85.183	BA85.183	BA85.183	BA85.183	BA85.183	BA85.183
5.	*Valve Plug Gasket	B159.167	B159.167	B159.167	B159.167	B159.167	B159.167
6.	Valve Plug	CB9.185-2	CB9.185-2	CB9.185-2	CB9.185-2	CB9.185-2	CB9.185-2
9.	*Release Valve "O" Ring	AJ100.312	AJ100.312	AJ100.312	AJ100.312	AJ100.312	AJ100.312
10.	Release Valve Spindle	AJ10.059	AJ10.059	AJ10.059	AJ10.059	AJ10.059	AJ10.059
11.	Cylinder	TC7.30	BA85.30-3	CB9.30-2	CB9.30-2	D87.30-2	EA11.30-1
12.	Plunger	TC7.40	BA85.40-4	AA85.40-3	AA85.40-3	D87.40-2	EA11.40-2
13.	Plunger Sleeve	TC7.39	BA85.39	AA85.39	AA85.39	D87.39	None
14.	Adjusting Screw	TC7.28	BA85.28-1	AA85.28-1	AA85.28-1	D87.28-2	None
14A.	Saddle	See Item 14	BA85.45-1	AA85.45-1	AA85.45-1	D87.45-3	EA11.45-1
15.	Plunger Ring	TC7.29	BA85.29-3	AA85.29-2	AA85.29-2	D87.29-2	EA11.29-1
16.	*Plunger Cup	TC7.41-1	1.41-1	M73-41-1	M73-41-1	D11.41-1	EA11.41-1
17.	Washer	TC7.43	BA85.43	AA85.43	AA85.43	D87.43	EA11.43-1
18.	Jam Nut	MJ35	MJ35	AA85.120	AA85.120	D87.120	EA11.120
19.	Reservoir	TC7.25	BA85.25-2	AA85.25-2	CB9.25-2	D87.25B	EA11.25A-2
20.	*Filler Gasket	C9.37	C9.37	C9.37	C9.37	C9.37	C9.37
21.	Filler Plug	C9.22-2	C9.22-2	C9.22-2	C9.22-2	C9.22-2	C9.22-2
22.	Top Cap	TC7.20-1	BA85.20-5	AA85.20-3	CB9.20-4	D87.20-2	EA11.20-2
23.	*Quad Ring	AJ100.214	CJ100.104	EJ100.102	EJ100.102	KJ100.090	NJ100.046
25.	*Pump Plunger	CB9.51-1	CB9.51-1	CB9.51-1	CB9.51-1	CB9.51-1	CB9.51-1
26.	*Pump Cup	F11.53	F11.53	F11.53	F11.53	F11.53	F11.53
27.	*Pump Cup Spreader	F11.52	F11.52	F11.52	F11.52	F11.52	F11.52
28.	*Retaining Nut	CB9.55	CB9.55	CB9.55	CB9.55	CB9.55	CB9.55
29.	Pump Cylinder	CB9.50-1	CB9.50-1	CB9.50-1	CB9.50-1	CB9.50-1	CB9.50-1
30.	Pump Packing	5.75S	5.75S	5.75S	5.75S	5.75S	5.75S
31.	Pump Gland Nut	CB9.54-1	CB9.54-1	CB9.54-1	CB9.54-1	CB9.54-1	CB9.54-1
32.	Beam	J19.60	J19.60	J19.60	J19.60	J19.60	J19.60
33.	Base Link Pin	BA85.57-1	BA85.57-1	BA85.57-1	BA85.57-1	BA85.57-1	BA85.57-1
34.	*Cotter Pin	1.58	1.58	1.58	1.58	1.58	1.58
35.	Link	BA85.62-2	BA85.62-2	BA85.62-2	BA85.62-2	BA85.62-2	BA85.62-2
36.	Beam Link Pin	TC7.57	TC7.57	TC7.57	TC7.57	TC7.57	TC7.57
37.	Beam Pin	J19.57	J19.57	J19.57	J19.57	J19.57	J19.57
38.	Handle	H-8 (One Pc.)	H-12	H-12	H-12	H-12	H-12
39.	Handle (Solid Section)		AJ100.100	AJ100.100	AJ100.100	AJ100.100	AJ100.100
40.	Handle (Tube Section)		AJ100.099	AJ100.099	AJ100.099	AJ100.099	AJ100.099
	Decal	AJ100.327	CJ100.113	EJ100.109	HJ100.058	KJ100.98	NJ100.025
	Beam Assembly (items 32-37)	AJ10.019	AJ10.019	AJ10.019	AJ10.019	AJ10.019	AJ10.019
	Pump Assembly (items 25-31)	CB9.50A-1	CB9.50A-1	CB9.50A-1	CB9.50A-1	CB9.50A-1	CB9.50A-1
	Jack/Saver Kit	TC-7K-3	BA-85K-3	AA-85K-3	CB-9K-3	D-8.7K-3	EA-11K-3

For economy repair, use Jack/Saver Kits. Items included in these Kits are marked with asterisk*.

Guarantee

Blackhawk guarantees its Lifting Equipment and Porto-Power Repair Tools against defects in workmanship and material for 90 days from date of delivery to the user. Only exception is chain, which follows the trade custom of its manufacturers and cannot be guaranteed.

When question of warranty arises, the user should send his unit to the nearest Blackhawk Franchised Service Depot for inspection, transportation to be prepaid and evidence of delivery date furnished. Contact Blackhawk Mfg. Co., Milwaukee, Wis., for list of Franchised Service Depots.

If the difficulty comes under the terms of our guarantee, the Franchised Service Depot will repair or replace parts affected and return prepaid. Our guarantee does not cover ordinary wear and tear, abuse, misuse, overloading, altered products or use of improper fluid.

Franchised Service Depots



For quality workmanship with genuine Blackhawk parts select a Franchised Blackhawk Service Depot for your repair work. Only repairs performed by a franchised service depot displaying this official franchise service depot sign are backed with full factory guarantee. The Classified Section in your Phone Book lists your nearest Franchised Service Depot.

BLACKHAWK MFG. CO.

MILWAUKEE 46, WISCONSIN

